

# MORTEX

M A N U F A C T U R I N G

Edition 12

Concrete Overlays - Drainage - Forms - Control Joints

# Table of Contents

<b>MORTEX</b>	1 Ordering 2 Knowledge about Kool Deck
<b>KOOL DECK OVERLAY</b>	3 Kool Deck Elite & Color Units 4 Keystone Kool Deck & Designer Colors 5 Kool Deck Technical Information
<b>KOOL DECK INSTRUCTIONS</b>	8 Kool Deck Elite - Fresh Concrete 11 Kool Deck Elite - Existing Concrete 16 Kool Deck Stamp 20 Keystone Kool Deck - Fresh Concrete 22 Keystone Kool Deck - Existing Concrete
<b>CONCRETE OVERLAY ACCESSORIES</b>	26 PTA Bonding Agent 27 Repair Kits 29 Deck Paint 31 Protect-a-Deck 32 Coping Mask 33 Commercial Cleaner 35 Tools & Accessories
<b>NEW - SOLEMENT OVERLAY</b>	36 Solement Overlay
<b>SYSTEX POLYMER DECK SYSTEM</b>	39 Systex Polymer Deck System 40 Technical Information 41 Instructions
<b>DRAINAGE</b>	43 Channel Rite 45 Drain Rite 47 Drain Rite Replacement Top 48 Drain Rite Accessories 49 Pave Rite & Accessories
<b>CONTROL JOINTS &amp; ACCESSORIES</b>	50 Control Joint 53 Control Joint Replacement Top 54 Foam Fiber Joints
<b>FORMING SYSTEMS &amp; ACCESSORIES</b>	55 Cantilever Forms - Gunite & Fiberglass 60 Form Dimensions 61 Form Accessories 62 Add-On's, Out Strips & One x Ones's 64 Automatic Pool Cover Forms 65 Brackit Form System 71 Forms for Fiberglass Pools w/ Angled Pool Walls 72 Rite Strip
<b>FORMING FOR VINYL LINER POOLS</b>	74 Key-Lock Forms - PVC Tracks & Aluminum Tracks
<b>OTHER FORM SYSTEMS</b>	76 Renovation Forms 77 Step Forms 78 Cornice Molding for Wall Tops 80 Countertop Forms



# Ordering & Terms & Conditions

***Mortex products are sold through our worldwide distribution network.***

**For the nearest sales location, contact Mortex at:**

**Phone: 1.800.338.3225 - Fax: 866.966.7839 - Email: [office@mortex.com](mailto:office@mortex.com)**

**PAYMENT & INVOICING:** Major credit cards or wire transfers are accepted unless a line of credit is established. Payment for orders shipping internationally are to be made by wire transfer.

Shipping charges for product will be added to the invoice unless otherwise denoted on your purchase order.

Accounts not paid within the payment terms listed on your invoice will be considered delinquent and delinquent accounts may be charged an interest at a rate of 1.5% per month. All invoices are subject to verification audit. Appropriate debits, credits and interest will be applied to all accounts.

Mistakes happen – We make every attempt to avoid errors in pricing and product information, but we are human. If a mistake does occur, we reserve the right to correct it and we apologize for any inconvenience it may cause.

Mortex cannot be held responsible for orders delayed by labor disputes, accidents, freight companies or any other cause beyond our control and reserves the right to claim force majeure in such occurrence.

There will be a \$50.00 charge on returned checks.

**BACK ORDERS:** Mortex will notify you if any product is not available for immediate shipment. Keep in mind some of our products are by special order only and may require 2-3 weeks lead time.

**FREIGHT:** Mortex ship product on our preferred freight carriers unless you instruct us otherwise, if applicable.

**INTERNATIONAL SHIPPING:** Mortex reserves the right to select the shipping company for all international orders.

**TRANSPORTATION CLAIMS:** Mortex's responsibility ceases when an order is turned over to a freight or package carrier or when the order is turned over to a customer and/or their representative. Should product be damaged in transit, it is the responsibility of the buyer/receiver to note the damaged or missing product on the freight carrier's delivery receipt when the merchandise is delivered. The buyer must also contact Mortex immediately to notify them of the damages. Mortex will make every effort to file a freight claim on the buyer's behalf.

**RETURNS:** If a return should become necessary, one **MUST** adhere to the following procedures. Before returning anything, call Mortex to discuss what you wish to return. Only unopened and undamaged containers are acceptable for return at a **20% restocking fee**. Any product or cartons that are returned damaged will result in a higher restocking fee to be determined at the time of the return. Any containers not received in an acceptable state for return will be destroyed by Mortex without credit to the customer. After discussing your return, Mortex will provide you with a Return Merchandise Form. Fax the completed form along with a copy of the invoice(s) indicating your purchase of the items you wish to return. Fax these to: 520-293-8884. When Mortex receives your completed Return Merchandise Form, Mortex will provide you with a Return Authorization Number (RAN) and the shipping address of where the product needs to be shipped back to. The RAN number only authorizes merchandise for return and does not guarantee acceptance or credit. You must write the RAN number on all boxes. Items must be sent freight Prepaid back to Mortex. Items received must match the list for which the RAN was issued. After inspection of the product, Mortex will issue a credit memo based on the accepted items from the RAN list, minus the appropriate restocking fees.

**\* NO RETURNS AFTER 90 DAYS OF PURCHASE \***

## **WARRANTY AND DISCLAIMER:**

Information contained herein is to our best knowledge, true and accurate but all recommendations or suggestions are made without guarantee. Since the conditions, usage and application of our products are beyond our control, Mortex disclaims any liability incurred in connection with the use of our products and information contained herein. No person is authorized to make any statement or recommendation not contained herein, and any such statement or recommendation so made shall not bind the company. Furthermore, nothing contained herein shall be construed as a recommendation to use any product, and no license implied or in fact is granted herein. Mortex further reserves the right to change terms, conditions, instructions or specifications of products described herein without notice.

# Let's Talk Kool Deck® Surfaces

## Demand the Original...

Kool Deck® concrete overlay was invented by Mortex in 1962. It is a beautiful surface for swimming pool decks, walkways, patios and virtually any foot traffic area. Once applied, it generates a colored, textured cement surface that is as strong as the base concrete.

- Significantly lowers the surface temperature of concrete.
- Withstands thermal expansion and contraction better than concrete.
- Requires minimal cleaning. Just rinse with water. When necessary, scrub with soap and water to keep the surface looking great.
- Proprietary mixture of natural substances and synthetic iron oxide pigments.
- Environmentally safe.
- Unaffected by normal pool chemicals.

## Kool Deck Today

Styles and tastes may change, but a cool surface for your feet in the heat of summer is always in fashion. Many of the decks done in the 70's, 80's and 90's are still around, looking great. Alternatives like polymer spray decking, pavers and travertine do not offer the low maintenance and cool longevity of a Kool Deck surface.

Kool Deck Stamp Release, represents the next wave of providing a modern format people are looking for with the function of our truly cool and skid-resistant material.

## Which Kool Deck® do I need?

**There are two different ways the Kool Deck product is packaged:**

- Kool Deck Elite: Pre-mixed in a 50 pound bag. Add only a color unit and water.
- Keystone Kool Deck: You must source your own marble sand and white cement.

**There are two options when Kool Deck surfaces can be applied:**

- On the very first day of the concrete pour (Fresh Concrete).
- On concrete that is at least 1 day old or beyond (Existing Concrete).

**There are two different methods to apply Kool Deck surfaces:**

- Dashed/Splashed, for the original Keystone look.
- Stamped, with Kool Deck Elite and our new Kool Deck Stamp Release.

	Kool Deck Elite	Keystone Kool Deck
Stamped	<p>Fresh Install</p> <p>Page 17</p> <p>Existing Slab</p> <p>Page 18</p>	<p>Not Supported</p>
Dashed (Keystone)	<p>Fresh Install</p> <p>Page 8</p> <p>Existing Slab</p> <p>Page 11</p>	<p>Fresh Install</p> <p>Page 20</p> <p>Existing Slab</p> <p>Page 22</p>



# Kool Deck® Elite™

When mixed with water and an entire Color-Unit™ pack, Kool Deck Elite forms a cementitious overlay for concrete. This elite product shares all the benefits you have come to expect from the genuine Kool Deck surface, like significantly lowering the surface temperature of concrete and being environmentally safe, but with an enhanced formula and the ease of a pre-mixed package that is bucket mixable.

- Significantly lowers the surface temperature of concrete.
- Perfect solution for barefoot area.
- Create a better surface while eliminating time and money spent sourcing proper size marble sand and white cement.
- Unparalleled value on per square foot basis.
- Performance, versatility and convenience for large and small decks.
- Mixable in a 5 or 6.5 gallon bucket.
- Basic 50 lb. pre-mixed bag - Just add water and a entire Color-Unit pack
- Enhanced formula for resistance to modern chemical attacks, craze cracking, etc.



Product Detail	Description
Coverage	A properly mixed bag should cover a minimum of 65 ft <sup>2</sup> (6 m <sup>2</sup> )
Contents	1 - 50 lb. Bag
Bag Measurements	14" x 19" x 4 1/2" (35.5 cm x 48.26 cm x 11.4 cm)
Weight	50 lbs (22.68 kg) - 52 lbs boxed
Shipping Information	UPS, FedEx, Freight Truck, Ocean or Air
Catalog Item #	Description
KDE	Kool Deck Elite

## Color Units

Color-Unit™ packs are the solution to consistent color proportioning. Kool Deck Elite and Solement™ are specifically made without color (white), so you can add the color you want, when you want it. These small 1 to 1.5 lb. bags come in all Kool Deck and Designer Color Palettes, and are easily added on a simple one Color-Unit pack to one 50 lb. bag of Kool Deck Elite or Solement.

- Perfectly proportioned color.
- Made from natural substances and synthetic iron oxide pigments.
- One Color-Unit pack per one bag of Kool Deck Elite.
- All colors match Kool Deck and Designer Color overlays.



Product Detail	Description		
Coverage	One Color-Unit pack contains proper amount of color for 1 - 50 lb. bag of Kool Deck Elite or Solement.	<b>Note:</b> Island Tan, Mauve, T5, and Terracotta are warmer to the touch due to their darker shade of color.	
Carton Contents	One carton contains 25 Color-Unit packs.		
Ctn Measurements	20" x 11" x 7" (50.8 cm x 27.9 cm x 17.7 cm)		
Weight	1 unit: 1 - 1 1/2 lbs each; Carton: 27 lbs to 29 lbs		
Shipping Information	UPS, FedEx, Freight Truck, Ocean or Air		
Catalog Item #	Description	Catalog Item #	Description
KDECUAB	Color-Unit - Adobe Buff	KDECUDIT	Color-Unit - Island Tan
KDECUAQ	Color-Unit - Aqua	KDECUDM	Color-Unit - Mauve
KDECUAG	Color-Unit - Aztec Gold	KDECURP	Color-Unit - Rose Pink
KDECUBG	Color-Unit - Birch Gray	KDECUSB	Color-Unit - Sand Buff
KDECUCP	Color-Unit - Coral Peach	KDECUST	Color-Unit - Sedona Tan
KDECUDG	Color-Unit - Dove Gray	KDECUDT5	Color-Unit - T5
KDECUDV	Color-Unit - Dust Devil	KDECUDTC	Color-Unit - Terracotta

# Keystone Kool Deck®

Keystone Kool Deck® concrete overlay was invented by Mortex in 1962. It is a beautiful surface for swimming pool decks, walkways, patios & virtually any foot traffic area. Once applied it generates a colored, textured cement surface that is as strong as the base concrete. **Note:** You must outsource your own white Portland cement and 20 mesh marble sand. See instructions.

- Significantly lowers the surface temperature of concrete.
- Cooler than regular concrete under similar conditions, making it a perfect solution for barefoot traffic areas.
- Withstands thermal expansion and contraction better than concrete.
- Proprietary mixture of natural substances and synthetic iron oxide pigments.
- Mixed in a paddle type mixer (not bucket mixable).



Product Detail	Description	Catalog Item #	Description
Coverage	A properly mixed unit covers a minimum of 300 ft <sup>2</sup> (28 m <sup>2</sup> ).	KDAB	Keystone Kool Deck - Adobe Buff
Ctn Contents	One carton contains 8 individual units (bags).	KDAG	Keystone Kool Deck - Aztec Gold
Ctn Measurements	16" x 16" x 11" (41 cm x 41 cm x 28 cm)	KDAQ	Keystone Kool Deck - Aqua
Weight	36 lbs (16.3 kg); Exceptions: Sedona Tan: 45 lbs (20.4 kg) White 30 lbs (13.6 kg)	KDBG	Keystone Kool Deck - Birch Gray
		KDCP	Keystone Kool Deck - Coral Peach
		KDRP	Keystone Kool Deck - Rose Pink
		KDSB	Keystone Kool Deck - Sand Buff
Shipping Information	UPS, FedEx, Freight Truck, Ocean or Air	KDST	Keystone Kool Deck - Sedona Tan
		KDWH	Keystone Kool Deck - White

## Designer Color Collection™

The Designer Color Collection™ are an extension of the Keystone Kool Deck color line. Made of the same durable formula as Mortex's classic Kool Deck overlays, the Designer Color Collection provides additional colors and a beautiful nonskid surface at the same low cost of the classic Kool Deck Colors. The colors of the Mortex Designer Color line are inspired by nature.

- Withstands thermal expansion and contraction better than concrete.
- Proprietary mixture of natural organic substances & synthetic iron oxide pigments.

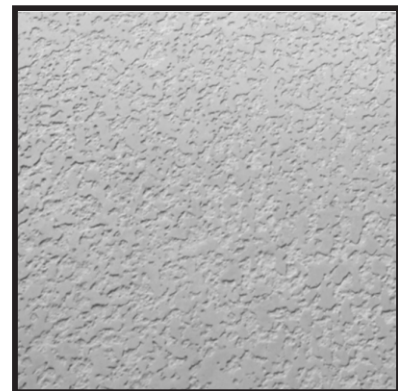

Product Detail	Description	Catalog Item #	Description
Coverage	A properly mixed unit should cover a minimum of 300 ft <sup>2</sup> (28 m <sup>2</sup> ).	DCM	Designer Color - Mauve
Contents	One carton contains 6 individual units (bags).	DCT5	Designer Color - T5
		DCTC	Designer Color - Terracotta
Ctn Measurements	16" x 16" x 11" (41 cm x 41 cm x 28 cm).		
Weight	Mauve & Terracotta: 47 lbs (21.3 kg); T5: 38 lbs (17.2 kg)		
Shipping Information	UPS, FedEx, Freight Truck, Ocean or Air		

**Note: Designer Colors are warmer to the touch than Kool Deck surfaces because of their darker shade.**

# Kool Deck® Elite™ and Keystone Kool Deck® Technical Information

## PRODUCT DESCRIPTION

KOOL DECK is purely cementitious overlay for concrete.

It is available in two form factors:

KOOL DECK ELITE (pre-mixed 50 pound bag) and

KEYSTONE KOOL DECK (powdered concentrate, requiring white cement and marble sand to be outsourced).

Both are ideal for applications where a non-skid, weather-resistant, low-maintenance colored product is desired. These products are cooler than regular concrete and painted surfaces under similar conditions, making it a perfect solution for barefoot traffic areas.

## INTENDED USE

KOOL DECK ELITE and KEYSTONE KOOL DECK are a concrete overlay, especially effective in areas where people are barefoot. Use it on walkways, patios, courtyards and swimming pool decks. It can be used on vertical surfaces as well as horizontal surfaces to significantly lower concrete surface temperatures.

## COMPOSITION AND MATERIALS

KOOL DECK ELITE and KEYSTONE KOOL DECK are composed of synthetic iron-oxide pigments, a proprietary mixture of natural and organic substances, marble sand and white cement. KOOL DECK ELITE and KEYSTONE KOOL DECK are manufactured with precise, quality control standards to ensure uniformity of color from bag-to-bag, batch-to-batch and year-to-year.

## LIMITATIONS

KOOL DECK ELITE and KEYSTONE KOOL DECK should not be mixed with any other ingredient except those specified in the instructions. These ingredients should be added in the prescribed order and blended in a plaster mixer with rubber wiper blades or a 5 gallon/6.5 gallon bucket to ensure uniform color mixing. Unused KOOL DECK ELITE and Color-Units should be stored in a dry place.

## TECHNICAL DATA

### APPLICABLE STANDARDS

KOOL DECK ELITE and KEYSTONE KOOL DECK performance when tested in accordance with:

### ASTM C109-77;

Compressive Strength: 2-inch cube specimens (50 mm)

- 1) 1300 pounds per square inch after 7 days curing time; within two standard deviations.
- 2) 1800 pounds per square inch after 14 days curing time; within two standard deviations.
- 3) 2800 pounds per square inch after 28 days curing time; within two standard deviations.

### ASTM C666-84;

Rapid Freezing and Thawing:

Beginning of failure of flat areas after 70 cycles.

### ASTM C944-85;

Abrasion Resistance:

- 1) Maximum 1-gram loss under 2-gram load, with 50 percent flat texture.
- 2) Maximum 3-gram loss under 6-gram load, with 50 percent flat texture.

### ASTM E303;

British Pendulum (BP) Surface Friction

Side	BPN
A	72
B	69
C	68
D	68

Average 69

# Kool Deck® Elite™ and Keystone Kool Deck® Technical Information

## COLORS

KOOL DECK ELITE and KEYSTONE KOOL DECK are available in eleven standard colors and four Designer Colors. The Designer Colors are warmer to the touch due to their darker shade. All colors are approximately represented on Mortex's color chart. Custom colors are available upon submittal of a color chip. Certain restrictions apply and a minimum purchase is required. With sufficient notice, our lab can prepare sample color chips for approval.

## WEATHER RESISTANCE

KOOL DECK ELITE and KEYSTONE KOOL DECK have excellent weatherability. KOOL DECK ELITE and KEYSTONE KOOL DECK both cure to a density and hardness that absorbs less water than standard concrete, giving it very good freeze/thaw durability. Surface deterioration from thermal stress does not occur because the coefficient of expansion and contraction are the same for both base and overlay. All of the ingredients in KOOL DECK ELITE and KEYSTONE KOOL DECK are unaffected by ozone or UV radiation as well as pool chemicals and chlorine.

## PATCHING KOOL DECK ELITE AND KEYSTONE KOOL DECK

Mortex produces a pre-mix repair kit for your convenience. Coverage is approximately 6 sq. ft. (.557m<sup>2</sup>). KOOL DECK Repair Kits can be ordered from your local distributor or call Mortex Corporate Headquarters for the name of a distributor.

## AVAILABILITY

KOOL DECK ELITE and KEYSTONE KOOL DECK are manufactured in Tucson, Arizona U.S.A. They are sold through our nationwide distribution network and to distributors abroad. Contact Mortex Corporate Headquarters for more information.

## MAINTENANCE

Wash the Kool Deck Elite or Keystone Kool Deck surface with water from a garden hose when dirt, leaves, etc., are found. The following are recommendations for common care:

- 1) Spills should be rinsed off immediately. Spills that result in a stain should be scrubbed with cleanser and water using a nylon scrub brush.
- 2) Stains can be cleaned with a granular electric dishwasher detergent such as Cascade™. Dilute the detergent in warm water, scrub with a nylon brush and rinse thoroughly. Be sure to wear rubber gloves when handling cleansers.
- 3) Mortex's Commercial Cleaner can be used to clean heavy stains, suntan lotions and body oils. Gray mineral deposits can collect on the surface over a period of time in heavily used areas such as steps, sprinkler heads and diving boards. These are caused by repeated water evaporation in the same area. Use Mortex's Commercial Cleaner with a floor scrubber and a 3M Scotch Brite stripping pad for these tough stains.
- 4) **If you have a Salt Water Chlorinator, it is essential that you rinse and clean your deck frequently.** Regular cleaning of your Kool Deck surface after use is an important part of the success of your deck. Other restrictions and suggestion may apply.



# Kool Deck® Elite™ and Keystone Kool Deck® Technical Information

## COLD WEATHER CONCRETING

- 1) Move to a six-bag mix.
- 2) Discuss using heated water and aggregates.
- 3) Use air-entrainment. (See Below.)
- 4) Be ready to take precautions if temperature drops below 45°F (7°C).  
**Note:** the first three days after the pour are critical.
- 5) Use hot water in the mix.
- 6) Use super plasticizers in the base concrete.

## HOT OR WINDY WEATHER CONCRETING

- 1) Consider a water reducer.
- 2) Wet sub grade, fog or sprinkle cool water on forms and reinforcing steel.
- 3) Schedule an early morning, evening or nighttime concrete placement.
- 4) Have sufficient workers to eliminate delays during construction.
- 5) Use ice water in the mix.
- 6) Erect wind breaks.

**KOOL DECK ELITE and KEYSTONE KOOL DECK and ADMIXTURES:** Mortex recommends that no item other than those listed in mixing instructions be added to the mix. Adding any other substance will alter the chemical balance and can lead to failure of the surface or bond.

**A. AIR-ENTRAINING ADMIXTURES:** The principal function of an air-entraining admixture is to improve the concrete's resistance to destruction due to freeze-thaw cycles. Air entrainment also reduces bleeding and segregation and normally will cause a slight reduction in concrete strength. In climates where concrete is subjected to freezing and thawing, an air-entrainment admixture is recommended for the base concrete. **Note:** You may use MasterAir AE 200 or GCP Applied DAREX II AEA.

Caution: Do not use lignosulfonate or vinsol resin based admixtures.

**B. CALCIUM CHLORIDE:** Calcium chloride's function is to accelerate the rate of strength development of concrete so that the need for protection against low ambient temperatures can be minimized. Calcium chloride or admixtures containing chloride ions can cause non-uniform color and should be avoided.

**C. WATER REDUCING ADMIXTURES:** Water reducing admixtures are organic materials added to the concrete mix to decrease the amount of water required to produce a workable mix. Generally stated, they can increase concrete strength and water tightness, improve workability and finishing results. **Note:** You may use super plasticizers that are Naphthalene or Melamine based.

**D. FIBER:** You may use any type of fiber in the base concrete as long as you avoid iron. Technical data and Material Safety Data Sheets on alternative products may be submitted to Mortex for consideration and/or lab approval. The only problem with fiber is the difficulty of mixing it into the concrete.

**GUIDELINES:** Arrival time of concrete: It is important that the scheduling of trucks is such that they arrive just before the concrete is required. This avoids excessive mixing of concrete while waiting.

## WARRANTY

Information contained herein is to our best knowledge, true and accurate but all recommendations or suggestions are made without guarantee. Since the conditions, usage and application of our products are beyond our control, Mortex disclaims any liability incurred in connection with the use of our products and information contained herein. No person is authorized to make any statement or recommendation not contained herein, and any such statement or recommendation so made shall not bind the company. Furthermore, nothing contained herein shall be construed as a recommendation to use any product, and no license implied or in fact is granted herein. *Mortex further reserves the right to change specifications of products described herein without notice.*

## INSTRUCTIONS FOR APPLYING KOOL DECK® ELITE ON THE VERY FIRST DAY OF THE CONCRETE POUR (FRESH CONCRETE)

Kool Deck Elite is a colorless (white) product. Use of an entire Mortex Color-Unit™ pack is required to achieve desired color.

### NECESSARY TOOLS FOR BUCKET MIXING

- Mortex Dash Brush
- Clean, 5 or 6.5 gallon Bucket (for mixing)
- 1 Gallon container (for measuring water)
- Heavy-Duty 3/4" Power Drill (300 rpm max)
- Rectangular Blade Mixing Paddle
- Steel Finishing trowels
- Mortex Viscosity Cup

Kool Deck Elite can easily be applied to existing concrete surfaces properly prepared with our PTA Bonding Agent, or to concrete on the very first day of the concrete pour (fresh concrete), as described below.

### REQUIRED MATERIALS

- 1 Color-Unit pack
- 1 Bag of Kool Deck Elite

### OPTIONAL TOOLS

- Paddle Type Mixer
- Mortex Pattern Blade

Temperature during pour: For best results, temperature during pour and application should take place when ambient temperature is above 50°F and below 90°F. **Caution:** If frost is predicted at any time during the first 72 hours after placement, the deck must be protected with a curing blanket.

### PREPARATION OF SOIL & SURROUNDINGS

- Be sure to grade so the deck will be uniform in thickness.
- Wet down the sub soil thoroughly just before the pour.
- Cover all walls and aluminum with plastic or paper. (Cement will corrode and blacken aluminum.)

### POURING THE SLAB

1. Order a five-bag mix, a little on the rocky side. A faster set and higher strength may be achieved with a six bag mix or lower slump.
2. When ordering concrete, stipulate that no additives are to be included in your concrete. Serious problems can result from the use of additives in conjunction with our product. When air-entrainment is necessary, consult with Mortex on the appropriate type to use.
3. After placing the concrete, tamp, and float. The finished deck will only be as level as the base concrete. Do not work bleed water into the surface.
4. Broom to scarify the entire slab. Use a nylon bristled push broom right behind the trowelling. Make only one pass. (Do not sweep loose sand to the surface, as this can cause a barrier between the concrete and the Kool Deck Elite.) Leave the mass concrete with open pores for bonding purposes, but not coarse enough that the roughness is revealed through the finished deck surface.

## MIXING OPTION 1: MIXING KOOL DECK ELITE IN A 5 or 6.5 GALLON BUCKET

1. Pour 1 gallon (3.79 L) of Water into Mixing Bucket.
2. Mix one (1) entire Color-Unit pack into Mixing water, using the heavy-duty drill with paddle blade. Dump entire 50 lb. bag of Kool Deck Elite into colored water while mixing.
3. Mix for two (2) minutes into an even colored, thick paste. Allow the mix to stand for one (1) minute.
4. Restart mixing. Slowly add an additional 2 gallons (7.57 L) of water to the mix.
5. Use a Mortex Viscosity Cup as a final guide on proper consistency. Mix should empty a full Viscosity Cup in 17 seconds for flat surfaces and 20 seconds for colder weather.

## MIXING OPTION 2: MIXING KOOL DECK ELITE IN A PADDLE TYPE MIXER

**Note:** A minimum of 3 bags of Kool Deck Elite is necessary per batch.

1. Start mixer and add 3 gallons (11.36 L) of water into the mixer.
2. Add 3 entire Color-Unit packs into the mixer.
3. Add 3 entire 50 lb. bags of Kool Deck Elite into the mixer.
4. Mix for three (3) minutes into an even colored, thick paste.
5. Slowly add up to an additional 6 gallons (22.7 L) of water to the mix.
6. Use a Mortex Viscosity Cup as a final guide on proper consistency. Mix should empty a full Viscosity Cup in 17 seconds for flat surfaces and 20 seconds for colder weather.

**WARNING:** Idle the mixer before checking the consistency of the mix with your Viscosity Cup. Never reach into a mixer with your body.

## SPLASHING THE KOOL DECK ELITE MIXTURE

1. Test the base concrete slab. The concrete base is ready for the surfacing to be applied when it can be walked on without leaving deep depressions, but still shows a water rise in foot impression.
2. Pour the mix from the mixing bucket or paddle mixer into a clean five gallon bucket.
3. Begin applying. Dip the brush into the mix covering the full length of the bristles and start splashing the mixture. If necessary, additional water should be added to the Kool Deck Elite mixture so the material will rain from the brush and have a creamy appearance when splashed. Use a Viscosity Cup according to instructions for best consistency.

**Suggestion:** The best texture is achieved by raising the brush high and moving the hand forward, snapping back with the wrist. This motion causes the mix to rain from the brush and gives an even, uniform texture.



4. Splash on the mixture in even, straight, side by side rows, being sure to overlap so as not to leave any holidays (unintentional gaps). The first splashing should be used to cover the deck.
5. Resplash the deck just before the first application has lost its water glaze. When applying a light second splash, allow the Kool Deck Elite mixture to rain down from the Dash Brush. The second splashing will drive the Kool Deck Elite surface into high peaks for good texture. The high texture produced by the second splash is necessary to allow trowelling time and to give a better pattern. Final material should be 1/8" total thickness.

**IMPORTANT NOTE:** Kool Deck Elite cannot be applied with a hopper gun! The material will separate from the air pressure, with the sand, cement and Kool Deck not adhere properly. You will get a failed surface with a false set, which will turn to powder over time.

**AFTER INSTALLATION:** Kool Deck surfaces need sufficient time to cure. The owner should avoid contact with the deck for 48 hours, light walking traffic after 3 days; normal walking traffic after 14 days; heavy patio furniture after 28 days.

## TROWELLING KOOL DECK ELITE

1. Begin to trowel as the water glaze leaves the deck. The pattern is set with the first trowel pass. The trowel must be held perfectly flat with a light hand. (The ideal tool is a Mortex Pattern Blade or a worn, cupped trowel.)
2. The second trowelling must follow immediately behind the first. With the trowel held flat, feel for un-even surface, leveling it as you go.
3. The second pass is necessary to bring the deck into a uniformly dense and colorfast deck surface. The finished deck should reveal approximately a 40% smooth and a 60% void surface. This prevents craze cracking since the knolls may expand and contract from the voids.

## COMPLETION OF WORK

1. Remove tape masking from joints and drains, clean up around the job site and you are finished.
2. A Kool Deck Elite surface applied to fresh concrete contains its own sealer and curing agents, so no further work on the deck surface is required.

**Note:** If you applied Kool Deck Elite to existing concrete using the PTA method, remember to cover the area with plastic after trowelling. Do not cover Kool Deck Elite with plastic if applied to fresh concrete.

**AFTER INSTALLATION** Light walking traffic after 3 days; Normal walking traffic after 14 days; heavy patio furniture and normal use after 28 days.

## POINTS TO REMEMBER

- Be sure to work the base concrete sufficiently. Areas left unworked are detrimental to a permanent bond.
- Make sure the Kool Deck Elite mixture is thin enough. A mixture that is too thick will result in low square foot coverage, poor finished pattern, an accelerated setting time, and more craze cracking. The Kool Deck Elite surface should be 1/8" thick.
- Apply the Kool Deck Elite mixture while there is still enough moisture in the base concrete to facilitate the bond and the curing of the Kool Deck Elite overlay.
- Splash twice. The first splashing should be used to cover the deck. The second splashing will drive the Kool Deck surface into high peaks for good texture.

## IN CASE OF RAIN OR OTHER UNFORESEEN DIFFICULTIES

Should it be necessary to cover the deck with plastic, be sure the plastic is removed as soon as possible. Failure to do so may result in a whitish film on the deck surface.



## REQUIRED MATERIALS

- Kool Deck Elite
- Color-Unit™ pack(s)
- PTA Bonding Agent
- Water

## NECESSARY TOOLS

- Mortex Dash Brush
- Clean, 5 gal/6.5 gallon Bucket (for mixing Kool Deck Elite)
- Clean, 5 gallon Bucket (for mixing PTA)
- 1 Gallon container (for measuring water)
- Heavy-Duty 3/4" Power Drill (300 rpm max)
- Rectangular Blade Mixing Paddle
- Steel Finishing trowels
- Mortex Viscosity Cup
- Nylon Bristle Broom
- Concrete finishing tools
- Pressure Washer
- Visqueen plastic sheeting (2 mil. clear)

## OPTIONAL TOOLS

- Paddle Type Mixer
- Mortex Pattern Blade

Kool Deck Elite can easily be applied to concrete on the very first day of the concrete pour (fresh concrete) or to existing concrete the next day after a pour and beyond as described here.

## COVERAGE

1 50 lb. bag of Kool Deck Elite will cover approximately 65 ft<sup>2</sup> when splashing and 30 ft<sup>2</sup> when stamping.

1 Color-Unit pack is required for every bag of Kool Deck Elite.

1 carton of PTA when mixed with water according to instructions will cover approximately 350 ft<sup>2</sup>.

Kool Deck Elite can easily be applied to concrete on the very first day of the concrete pour (fresh concrete) or to existing concrete the next day after a pour and beyond as described below.

Kool Deck Elite is a colorless (white) product. Use of an entire Mortex Color-Unit pack is required to achieve desired color.

**IMPORTANT:** Mortex Manufacturing highly recommends a trained crew of 4 – 5 people apply Kool Deck Elite in a splashed application.

## BASIC STEPS

1. Remove any existing overlays or foreign matter from the deck.
2. Wash the deck with a water & muratic acid solution followed by a high pressure wash.
3. Apply PTA Bonding Agent.
4. Apply Kool Deck Elite.
5. Splash and Trowel.
6. Cover with plastic for two days.
7. Remove plastic and clean up site.
8. Enjoy.



## DETAILED INSTRUCTIONS

**SAFETY:** Proper safety considerations should be followed during the application of Mortex products and any product should be used in accordance with the SDS (Safety Data Sheets) and all recommendations followed.

**TEMPERATURE CONSIDERATIONS:** For best results, ambient temperature during the **application should be 50 degrees and rising and should not be over 90 degrees.**

**Note:** In warm climates, extreme care should be taken if installation is to take place when temperatures are expected to exceed 90°F. This is due to the necessity of the overlay to cure after application. In freeze-thaw climates, the finished application should be protected against frost and other severe conditions, for a period of 28 days.

If rain or frost is predicted then.....do not apply the products.

## CLEAN AND PREPARE CONCRETE

Preparation of the concrete surface is one of the most important factors in the successful use of the PTA Bonding Agent followed by the application of a Kool Deck surface (PTA System). The performances of our products are directly related to how well the surface has been prepared.

The PTA System will only adhere to solid concrete surfaces. Mortex does not recommend that our overlay be applied to brick, wood, tile, natural stone, clay or any other surface that is not cementitious as proper adhesion will not occur.

The PTA System will also not adhere to any concrete substrate that is not completely free of dirt, grime, oil, wax, grease, paints, stains, loose overlays, deteriorated concrete, curing compounds or any other foreign matter.

**Note:** When evaluating the amount of deck preparation work necessary and the question comes up of whether or not you have done enough, the answer is "The More You Do, The Better the Job."

## SURFACE PREPARATION

1. Application of PTA System should only be to clean, sound concrete surfaces that are next day after a pour or older.
2. Mask off all areas that are not being coated to protect them from damage. Mask exposed aluminum surfaces and all areas that you wish to protect from over splash. (Cement will corrode and blacken aluminum.) Cover joints and drains with protective tape.
3. Remove deteriorated concrete or other overlays using a scarifier first, then a power washer to remove debris. A 3000 psi pressure washer can be used to remove any paints, plastic coatings, adhesives or polymer overlays.
4. Repair any major cracks or deteriorated areas in the concrete well in advance. Any major repairs of structural damage in the deck or cracks should be done well in advance of the PTA and overlay application. Any minor repairs such as damaged edges and/or depressions and holes should be made just ahead of surface application.
5. Wet the deck with water in preparation of the muriatic acid wash. Concrete must be acid washed with a strong solution of muriatic acid to etch the surface. Never put acid on dry concrete.
6. Mix and apply muriatic acid solution: For older concrete, use an acid solution: 1 part acid to 1 part water. For new concrete, use 1 part acid to 4 parts water. It is NOT necessary to neutralize the acid with products such as Trisodium Phosphate (TSP). It is important to understand that neutralizers like TSP or Baking Soda will leave a film on the deck and will break the bond between the concrete deck and the deck overlay. Apply acid, scrub with a nylon bristly floor broom. Allow acid to thoroughly exhaust itself, with no visible bubbling on the deck before rinsing.
7. Use a nylon bristle broom to scrub into surface.

**Note:** When the acid is applied, if the acid does not boil and bubble then there is still something on the deck.

8. Rinse exhausted acid residue off by using a 3000 psi pressure washer with the nozzle 3-4 inches off the deck.
9. Follow with an additional pressure wash to rinse away dislodged debris. This time hold the pressure washer nozzle 1 foot from the deck surface.

**REMEMBER:** Do not neutralize the deck with neutralizers such as TSP or Baking Soda as the Kool Deck material will not bond to them.

10. Before the application of the PTA Bonding Agent the deck must be kept wet for a period of at least one (1) hour prior to using PTA.
11. Minor repairs such as damaged edges and/or depressions and holes, should be made at this time. Repair should be damp but without standing water. Brush PTA only into the area to be repaired. Using a rubber float as an applicator, pack holes and depressions with the overlay mixture in a thick enough consistency to avoid craze cracking.

### MIX & COAT THE SURFACE WITH THE PTA BONDING AGENT

**REMEMBER:** Before the application of the PTA Bonding Agent the deck must be kept wet for a period of at least one (1) hour prior to using PTA.

Mixing Formula – Follow carefully

- 1 Carton of PTA
- 1.3 Gallons (5 L) water

1. Place 0.5 gallon (2 L) of water in a 5 gallon bucket and add PTA; mix for two minutes with a drill and a rectangular mixing blade. Let mixture rest for three minutes.
2. Add remaining 0.8 gallon (3 L) of water and blend for three additional minutes until proper consistency is obtained.
3. When mixed with water, PTA should have the consistency of milk. Additional water can be added to maintain consistency. Apply more PTA onto needed areas.

### APPLICATION OF PTA INSTRUCTIONS

1. Pour PTA onto deck and use a broom to scrub PTA onto the entire surface (including the repair area). Be sure to cover surface completely.

**VERY IMPORTANT: DO NOT ALLOW PTA TO DRY BEFORE THE KOOL DECK ELITE MATERIAL IS APPLIED.**

2. Brush away all excess PTA. Base concrete should be visible through the PTA (thin coat is best).

### MIXING OPTION 1: MIXING KOOL DECK ELITE IN A 5 or 6.5 GALLON BUCKET

1. Pour 1 gallon (3.79 L) of Water into Mixing Bucket.
2. Mix one (1) entire Color-Unit pack into Mixing water, using the heavy-duty drill with paddle blade.
3. Gradually dump entire 50 lb. bag of Kool Deck Elite into colored water while mixing.
4. Mix for two (2) minutes into an even colored, thick paste. Allow the mix to stand for one (1) minute.
5. Restart mixing. Slowly add an additional 2 gallons (7.57 L) of Water to the mix.
6. Use a Mortex Viscosity Cup as a final guide on proper consistency. Mix should empty a full Viscosity Cup in 17 seconds for flat surfaces and 20 seconds for colder weather.



### MIXING OPTION 2: MIXING KOOL DECK ELITE IN A PADDLE TYPE MIXER

**Note:** A minimum of 3 bags of Kool Deck Elite is necessary per batch.

1. Start mixer and add 3 gallons (11.36 L) of water into the mixer.
2. Add 3 entire Color-Unit packs into the mixer.
3. Add 3 entire 50 lb. bags of Kool Deck Elite into the mixer.
4. Mix for three (3) minutes into an even colored, thick paste.
5. Slowly add up to an additional 6 gallons (22.7 L) of Water to the mix.
6. Use a Mortex Viscosity Cup as a final guide on proper consistency. Mix should empty a full Viscosity Cup in 17 seconds for flat surfaces and 20 seconds for colder weather.

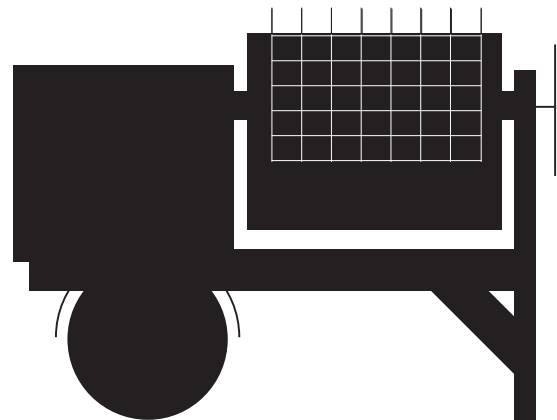

**WARNING:** Idle the mixer before checking the consistency of the mix with your Viscosity Cup. Never reach into a mixer with your body.



### SPLASHING THE KOOL DECK ELITE MIXTURE

1. Pour the mix from the mixing bucket or paddle mixer into a clean five gallon bucket.
2. Begin applying. Dip the brush into the mix covering the full length of the bristles and start splashing the mixture. If necessary, additional water should be added to the Kool Deck Elite mixture so the material will rain from the brush and have a creamy appearance when splashed. Use a Viscosity Cup according to instructions for best consistency.
3. Splash on the mixture in even, straight, side by side rows, being sure to overlap so as not to leave any holidays (unintentional gaps). The first splashing should be used to cover the deck.

**Suggestion:** The best texture is achieved by raising the brush high and moving the hand forward, snapping back with the wrist. This motion causes the mix to rain from the brush and gives an even, uniform texture.



4. Resplash the deck just before the first application has lost its water glaze. When applying a light second splash, allow the Kool Deck Elite mixture to rain down from the Dash Brush. The second splashing will drive the Kool Deck Elite surface into high peaks for good texture. The high texture produced by the second splash is necessary to allow trowelling time and to give a better pattern. Final material should be 1/8" total thickness.

**Note: Kool Deck Elite can NOT be applied with hopper gun. A hopper will separate the sand and cement and the Kool Deck material will not adhere properly.**

### TROWELLING KOOL DECK ELITE

1. Begin to trowel as the water glaze leaves the deck. The pattern is set with the first trowel pass. The trowel must be held perfectly flat with a light hand. (The ideal tool is a Mortex Pattern Blade or a worn, cupped trowel.)
2. The second trowelling must follow immediately behind the first. With the trowel held flat, feel for uneven surface, leveling it as you go.
3. The second pass is necessary to bring the deck into a uniformly dense and colorfast deck surface. The finished deck should reveal approximately a 40% smooth and a 60% void surface. This prevents craze cracking since the knolls may expand and contract from the voids.

### CURE WITH PLASTIC

**VERY IMPORTANT:** Immediately after final trowelling, cover area with Visqueen (aka Polyethylene Plastic) 2 mil. clear in color and leave covered for precisely two (2) days. Cover the areas immediately with plastic after trowelling. Do not wait until you have completed the entire job before covering with plastic. Weight the plastic down with sand so that air cannot circulate under the plastic and dry out the deck. Do not leave covered for more than two (2) days. If the deck surface exhibits white growths when the plastic is removed, wash the surface with water immediately. Use a stiff bristle nylon brush to scrub the surface. During the next 28 days, the deck surface should be washed frequently.

### AFTER INSTALLATION

Kool Deck surfaces need sufficient time to cure. The owner should avoid contact with the deck for 48 hours, light walking traffic after 3 days; normal walking traffic after 14 days; heavy patio furniture after 28 days.

# Kool Deck® Stamp Release

Kool Deck Stamp Release is a revolutionary means to applying Kool Deck by stamping. This release is a versatile, dry bond breaker for exclusive use with Kool Deck Elite and modern “seamless skin” stamp pads. Without Silica or Talc, this material is 2017 OSHA compliant and is designed excellent results with better coverage.

- Great coverage with thin application for realistic results.
- Non-toxic, biodegradable and white in color for no mess.
- Applied easily with Mortex Sifting applicator.
- Removal with a stiff bristled brush or pressure washer.
- Does not increase temperature of final deck surface.



Product Detail	Description
Coverage - Release	1100 to 1300 ft <sup>2</sup> per 11 lb net (102 to 121 m <sup>2</sup> per 5 kg)
Coverage - Kool Deck Elite	30 sq. ft per bag @ 3/16" thickness
Contents	5 gallon bucket
Carton Measurements	12" diameter x 15" H (30.5 cm x 38 cm)
Weight	14 lbs (6.35 kg)
Shipping Information	UPS, FedEx, Freight Truck, Ocean or Air

Catalog Item #	Description
KXSR	Kool Deck Stamp Release
KXSRS	Stamp Release Sifter
PXSHANDK	Stamp Pad 16" x 22" - Hand Stamp - Kool Deck Stamp
PXSKOOL34	Stamp Pad 3' x 4' - Kool Deck Stamp
KXSRS	Stamp Release Sifter
T65GB	6.5 Gallon Bucket

## INSTRUCTIONS:

Before water glaze has fully evaporated, lightly disperse the Kool Deck Stamp Release on the surface using only a Mortex Release Sifter. Do not apply with brush or hand.



# Kool Deck® Elite™ Stamping Instructions

**Kool Deck can be stamped on either fresh concrete (first day of the concrete pour) or existing concrete as described below.**

## **INSTRUCTIONS - EXISTING CONCRETE**

### **Preparation of Existing Concrete Slab**

A clean, sound concrete surface is required. The concrete must be free from dirt, stains, paints, loose overlays and/or deteriorated concrete that may be on the surface of the base concrete.

**Note:** When evaluating the amount of deck preparation work necessary and the question comes up of whether or not you have done enough, the answer is “The More You Do, The Better the Job.”

Mask exposed aluminium surfaces and all areas that you wish to protect. (Cement will corrode and blacken aluminium.) Cover joints and drains with protective tape.

Any major repairs of structural damage in the deck or cracks should be done well in advance of the PTA Bonding Agent and stamping application. Any minor repairs such as damaged edges and/or depressions and holes should be made just ahead of surface application.

Any deteriorated concrete and other overlays should be removed using a scarifier first, then a power washer to remove stubborn debris.

**Acid Wash:** All concrete must be acid washed with a strong solution of muriatic acid to etch the surface. Never put acid on dry concrete. For older concrete, use an acid solution: 1 part acid to 1 part water. For new concrete, use a 1 part acid to 4 parts water. Do NOT neutralize residual acid (if any) with Trisodium Phosphate (TSP). It is important to understand that any neutralizers like TSP or Baking Soda will leave a film on the deck and will break the bond between the concrete deck and the deck overlay. Apply acid solution, and scrub with a nylon bristle floor broom. Allow acid to thoroughly exhaust itself, with no visible bubbling on the deck before rinsing.

Thoroughly rinse the acid washing residue from the deck with a pressure washer at 3000psi. Keep the entire surface wet for a period of at least one (1) hour prior to using PTA. Before applying the PTA, the area should be thoroughly damp, with no standing water.

## **MIX & COAT THE SURFACE WITH THE PTA BONDING AGENT**

Mixing Formula – Follow carefully

- 1 Carton of PTA
- 1.3 Gallons (5 L) water

1. Place 0.5 gallon (2 L) of water in a 5 gallon bucket and add PTA; mix for two minutes with a drill and a rectangular mixing blade. Let mixture rest for three minutes.
2. Add remaining 0.8 gallon (3 L) of water and blend for three additional minutes until proper consistency is obtained.
3. When mixed with water, PTA should have the consistency of milk. Additional water can be added to maintain consistency. Pot life is a maximum of 45 minutes.

## **APPLICATION OF THE PTA BONDING AGENT**

1. At the time PTA is applied, the area to receive the mixture should be thoroughly damp, with no standing water.
2. If small repairs are being made, brush PTA only into the area to be repaired. Then use a rubber float as an applicator and pack holes or depressions with the overlay (Kool Deck Elite) mixture in a stiff paste form consistency to avoid craze cracking (dry pack).
3. Next use a broom to scrub PTA onto the entire surface (including surface of repaired areas). Be sure to cover surface completely.

# Kool Deck® Elite™ Stamping Instructions

4. Brush away all excess PTA. Base concrete should be visible through the PTA (thin coat is best).
5. **VERY IMPORTANT: DO NOT ALLOW PTA TO DRY BEFORE THE KOOL DECK ELITE MATERIAL IS APPLIED.** Apply more PTA onto needed areas and brush it across the surface to maintain moisture.

## MIXING AND APPLICATION OF KOOL DECK ELITE FOR STAMPING APPLICATION (FOR NEW OR EXISTING CONCRETE)

The Kool Deck Elite premix product is exclusively approved for use in stamping applications. Mixing Kool Deck Elite for stamping applications is different in that significantly less water is used.

### OPTION 1: MIXING KOOL DECK ELITE IN A 5 GALLON BUCKET FOR STAMPING (FOLLOW CAREFULLY)

1. Pour one (1) gallon (3.79 L) of Water into Mixing Bucket.
2. Mix one (1) entire Color-Unit pack into mixing water, using the heavy-duty drill with paddle blade.
3. Slowly add one (1) entire 50 lb bag of Kool Deck Elite into colored water while mixing
4. Thoroughly mix for two (2) minutes into an even colored paste. Allow the mix to stand for one (1) minute.
5. Restart mixing. Slowly add an additional one (1) quart (.95 L) of water to the mix until uniform consistency.

### OPTION 2: MIXING KOOL DECK ELITE IN A PADDLE TYPE MIXER FOR STAMPING

**Note:** A minimum of four (4) bags of Kool Deck Elite are necessary per mixer batch. This method is recommended for areas of more than 120 square feet.

1. Start mixer and add four (4) gallons (15.14 L) of water into the mixer.
2. Add four (4) Color-Unit packs into the mixer, mix for 30 seconds to color water.
3. Add four (4) 50 lb bags of Kool Deck Elite into the mixer.
4. Mix for three (3) minutes into an even colored paste.
5. Pour one (1) gallon (3.79 L) of additional Water into the mixer.
6. Mix for additional one (1) minute, check for uniform consistency.

### KOOL DECK STAMP MATERIAL APPLICATION FOR STAMPING

1. Pour mixture from a bucket onto damp PTA covered surface or fresh concrete directly.
2. Cover cantilever edges first with a trowel, then use gauge rake to distribute material to a **3/16" thickness** across the horizontal surfaces.
3. Using a wooden/magnesium float in colder weather and steel trowel in warmer weather, float or trowel to fill in gauge rake marks and smooth surface.
4. Allow some of the KDE water glaze to evaporate slightly before lightly dusting the surface with Mortex Kool Deck Stamp Release using a Mortex Release Sifter. Do NOT apply with brush or hand. Distribute Release on surface in an even layer, using a **light-duty leaf blower**.

**Caution:** Only allow release to contact KDE material covered areas, as Stamp Release will inhibit adhesion of underlying concrete to PTA or KDE overlay.

# Kool Deck® Elite™ Stamping Instructions

## STAMPING KOOL DECK ELITE

5. Once the Kool Deck material has hardened sufficiently, proper timing of stamping is determined by pressing a thumb into the surface. The Kool Deck material will be ready when it requires moderate force for impression, leaving no residual material on finger.
  - a. Using industry stamp pads that have no more than 1/8" depth of impression:
    - i. Address edges and areas that are earlier in hardening with a smaller pad and dead-blow hammer to stamp pad into surface.
    - ii. Using larger pads, place on surface and stamp with tamper in overlapping rows coming no closer than one half tamper width away from any pad edge.
  - b. Use an overlapping methodology with two adjacent pads, stamping first on one, and then alternating which is below adjacent pad, then stamping that pad.
  - c. Be consistent. Check for level of impression while stamp pad is pinned in-place on surface before moving on. See Points to Remember for further suggestions.

## POINTS TO REMEMBER / TROUBLESHOOTING

1. If material adheres to the stamp pad, water is penetrating the release film. Is is primarily caused by stamping too early or stamping too hard. To correct this issue while stamping:
  - a. Sift a light amount of Stamp Release to affected surface area; Stamp only once more.
  - b. Remove pad and allow pad to dry residual KDE material. Broom/brush off material on pad. Do not smear wet material on pad.
2. Do not leave pads for any extended time. This will causing wicking.
3. Rotate stamp pads 90 degrees throughout process to maximize randomness of pattern.
4. Using too much Stamp Release will reduce fidelity of pad surface.

## CURE WITH PLASTIC

**VERY IMPORTANT:** Immediately after final stamping, cover area with Visqueen (aka Polyethylene Plastic) 2 mil. clear in color and leave covered for precisely two (2) days. Do not wait until you have completed the entire job before covering with plastic. Weight the plastic down with sand so that air cannot circulate under the plastic and dry out the deck. Do not leave covered for more than two (2) days.

When removing plastic, wash the surface with water immediately. Use a stiff bristle nylon brush to scrub the surface to remove residue from Mortex Stamp Release. Use of a pressure washer to remove stubborn or excessive residue may be necessary or easier. Exercise caution with pressure wand to not damage new surface by operating too close to the surface.

During the next 28 days, wash the deck frequently to increase hardness.

Remove tape masking from joints and drains, clean up around the job site and you are finished. Remind the deck owner to avoid traversing and placing furniture on the deck until the deck has had time to harden and cure sufficiently to warrant general use.

**Protect-A-Deck** waterproofing agent is highly recommended for any Kool Deck application to help mitigate staining and enhance performance. Remove all Stamp Release residue and properly clean surface before applying Protect-A-Deck.

## AFTER INSTALLATION

Recommendations for client after installation: Light walking traffic after 3 days; Normal walking traffic after 14 days; heavy patio furniture and normal use after 28 days. Remember over the next 28 day wash the deck frequently to increase hardness.

### NECESSARY TOOLS

- Mortex Dash Brush
- Paddle type plaster mixer
- 5-Gallon buckets
- Steel Finishing trowels

Keystone Kool Deck can easily be applied to existing concrete surfaces properly prepared with our PTA Bonding Agent or to concrete on the very first day of the concrete pour (fresh concrete) as described below.

### OPTIONAL TOOLS

- Mortex Viscosity Cup
- Mortex Pattern Blade

### SURFACE REQUIREMENTS

- Be sure to grade so the deck will be uniform in thickness.
- Wet down the sub soil thoroughly just before the pour.
- Cover all walls and aluminum with plastic or paper. (Cement will corrode and blacken aluminum.)

### POURING THE SLAB

1. Order a five-bag mix, a little on the rocky side. A faster cure and higher strength may be achieved with a six bag mix.
2. When ordering concrete, stipulate that no additives are to be included in your concrete. Serious problems can result from the use of additives in conjunction with our product. When air-entrainment is necessary, consult with Mortex on the appropriate type to use.
3. After placing the concrete, tamping, and floating, continue to work with the concrete. Good compaction will result in a suitable base. The finished deck will only be as level as the base concrete.
4. Broom to scarify the entire slab. Use a nylon bristled push broom right behind the trowelling. Make only one pass. (Do not sweep loose sand to the surface, as this can cause a barrier between the concrete and the Keystone Kool Deck surface.) Leave the mass concrete with open pores for bonding purposes, but not coarse enough that the roughness is revealed through the finished deck surface.

### MIXING THE KOOL DECK® OVERLAY (FOLLOW CAREFULLY)

The Formula:

- 1 Unit Keystone Kool Deck
- 1 Bag White Cement (94 lbs.)
- 10 Gallons size 20 mesh marble sand (130 lbs.)
- 8 Gallons water

**Note:** A paddle type mixer is necessary for a thorough, uniform blend.

1. Deposit the marble sand into mixer; add just enough water to dampen the sand (1 gallon).
2. Add one Kool Deck unit. Allow this to mix for at least two minutes.
3. Add water (4 gallons) and white cement simultaneously. Allow this stiff paste to turn for three minutes.
4. Add additional water (3 gallons) until the mixture is of a "milky" consistency. If necessary, slightly more water should be added to achieve a thin, milky mixture. Use a viscosity cup to help obtain proper consistency.

### SPLASHING THE KEYSTONE KOOL DECK MIXTURE

1. Test the base concrete slab. The concrete base is ready for the surfacing to be applied when it can be walked on without leaving deep depressions, but still shows a water rise when pressed.
2. Pour the mix from the mixer into a five gallon bucket.
3. Begin applying. Dip the brush into the mix covering the full length of the bristles and start splashing the mixture. If necessary, additional water should be added to the Keystone Kool Deck mixture so the material will rain from the brush and have a creamy appearance when splashed. The best texture is achieved by raising the brush high and moving the hand forward, snapping back with the wrist. This motion causes the mix to rain from the brush and gives an even, uniform texture.

4. Splash on the mixture in even, straight, side by side rows, being sure to overlap so as not to leave any holidays.
5. Resplash the deck just before the first application has lost its water glaze. When applying the second coat, allow the Kool Deck mixture to rain down from the Dash Brush. The high texture produced by the second splash is necessary to allow trowelling time and to give a better pattern.

**Note:** The total material thickness should be 1/8".

### TROWELLING THE KEYSTONE KOOL DECK SURFACE

1. Begin to trowel as the water glaze leaves the deck. The pattern is set with the first trowel pass. The trowel must be held perfectly flat with a light hand. (The ideal tool is a Mortex Pattern Blade or a worn, cupped trowel)
2. The second trowelling must follow immediately behind the first. With the trowel held flat, feel for uneven surface, leveling it as you go.
3. A last pass may be necessary to bring the deck into a uniformly dense and color-fast deck surface. The finished deck should reveal approximately a 40% smooth and a 60% void surface. This prevents craze cracking since the knolls may expand and contract from the voids.

### COMPLETION OF WORK

1. Remove tape masking from joints and drains, clean up around the job site and you are finished.
2. A Kool Deck surface applied to fresh concrete contains its own sealer and curing agents, so no further work on the deck surface is required.

**Note:** If you applied Keystone Kool Deck to existing concrete using the PTA method, remember to cover with plastic after trowelling. DO NOT cover with plastic if applied to green concrete as just described.

3. Remind the deck owner to avoid traversing and placing furniture on the deck until the deck has had time to harden and cure sufficiently to warrant general use. (Approximately 28 days)

### AFTER INSTALLATION

Kool Deck surfaces need sufficient time to cure. The owner should avoid contact with the deck for 48 hours, light walking traffic after 3 days; normal walking traffic after 14 days; heavy patio furniture after 28 days.

### POINTS TO REMEMBER

- Be sure to work the base concrete sufficiently. Areas left unworked are detrimental to a permanent bond.
- Make sure the Keystone Kool Deck mixture is thin enough. A mixture that is too thick will result in low square foot coverage, poor finished pattern, an accelerated setting time, and more craze cracking. The best Keystone Kool Deck surface is not more than 1/8 inch thick.
- Apply the Kool Deck mixture while there is still enough moisture in the base concrete to facilitate the curing of the Keystone Kool Deck overlay. This will help prevent fast drying.
- Splash twice. The first splashing should be used to cover the deck. The second splashing will drive the Keystone Kool Deck surface into high peaks for good texture.

### IN CASE OF RAIN OR OTHER UNFORESEEN DIFFICULTIES

Should it be necessary to cover the deck with plastic, be sure the plastic is removed as soon as possible. Failure to do so may result in a whitish film on the deck surface.

**IMPORTANT NOTE:** Keystone Kool Deck and Kool Deck Elite should NOT be applied with a hopper gun. The material will clog the hopper. A hopper will separate the sand and cement and the Kool Deck material will not adhere properly. You will get a false set. At first the Kool Deck surface will seem as if it will set properly, but it will not hold up over time.

### REQUIRED MATERIALS

- Keystone Kool Deck
- PTA Bonding Agent
- Water
- 20 Mesh Marble Sand
- White Portland Cement

### OPTIONAL TOOLS

- Mortex Pattern Blade

### NECESSARY TOOLS

- Paddle Type Concrete Mixer
- Mortex Dash Brush
- Clean, 5 gallon Bucket
- 1 Gallon container (for measuring water)
- Steel Finishing trowels
- Mortex Viscosity Cup
- Nylon Bristle Broom
- Concrete finishing tools
- Drill with mixing blade
- Pressure washer



### COVERAGE

1 unit of Keystone Kool Deck will cover approximately 300 ft<sup>2</sup>.

1 carton of PTA will cover approximately 350 ft<sup>2</sup>.

**Keystone Kool Deck can easily be applied to concrete on the very first day of the concrete pour (fresh concrete) or to existing concrete the next day after a pour and beyond as described here.**

### IMPORTANT:

**Mortex Manufacturing highly recommends a trained crew of 4 – 5 people apply Keystone Kool Deck.**

### BASIC STEPS

1. Remove any existing overlays or foreign matter from the deck.
2. Wash the deck with a water & muriatic acid solution followed by a high pressure wash.
3. Apply PTA Bonding Agent.
4. Splash Keystone Kool Deck material.
5. Trowel.
6. Cover with plastic for two days.
7. Remove plastic and clean up site.
8. Enjoy.

### DETAILED INSTRUCTIONS

**SAFETY:** Proper safety considerations should be followed during the application of Mortex products and any product should be used in accordance with the SDS (Safety Data Sheet) and all recommendations followed.

**TEMPERATURE CONSIDERATIONS:** For best results, ambient temperature during the application should be 50 degrees and rising and should not be over 90 degrees.

**Note:** In warm climates, extreme care should be taken if installation is to take place when temperatures are expected to exceed 95°F (35°C.) This is due to the necessity of the overlay to cure after application. In freeze-thaw climates, the finished application should be protected against frost and other severe conditions, for a period of 28 days.

If rain, frost or snow is predicted then.....do not apply the products.



### CLEAN AND PREPARE CONCRETE

Preparation of the concrete surface is one of the most important factors in the successful use of the PTA Bonding Agent followed by the application of a Kool Deck surface (PTA System). The performances of our products are directly related to how well the surface has been prepared.

The PTA System will only adhere to solid concrete surfaces. Mortex does not recommend that our overlay be applied to brick, wood, tile, natural stone, clay or any other surface that is not cementitious as proper adhesion will not occur.

The PTA System will also not adhere to any concrete substrate that is not completely free of dirt, grime, oil, wax, grease, paints, stains, loose overlays, deteriorated concrete, curing compounds or any other foreign matter.

**Note:** When evaluating the amount of deck preparation work necessary and the question comes up of whether or not you have done enough, the answer is “The More You Do, The Better the Job.”

### SURFACE PREPARATION

1. Application of PTA System should only be to clean, sound concrete surfaces.
2. Mask off all areas that are not being coated to protect them from damage. Mask exposed aluminum surfaces and all areas that you wish to protect from over splash. (Cement will corrode and blacken aluminum.) Cover joints and drains with protective tape.
3. Remove deteriorated concrete or other overlays using a scarifier first, then a power washer to remove debris. A 3000 psi pressure washer can be used to remove any paints, plastic coatings, adhesives or polymer overlays.
4. Repair any major cracks or deteriorated areas in the concrete well in advance. Any major repairs of structural damage in the deck or cracks should be done well in advance of the PTA and overlay application. Any minor repairs such as damaged edges and/or depressions and holes should be made just ahead of surface application.
5. Wet the deck with water in preparation of the muriatic acid wash. All concrete (even 1 day old, fresh concrete) must be acid washed with a strong solution of muriatic acid to etch the surface. Never put acid on dry concrete.
6. Mix and apply muriatic acid solution: For older concrete, use an acid solution: 1 part acid to 1 part water. For new concrete, use a 1 part acid to 4 parts water. It is NOT necessary to neutralize the acid with products such as Trisodium phosphate (TSP). It is important to understand that neutralizers like TSP will leave a film on the deck and will break the bond between the concrete deck and the deck overlay.
7. Use a nylon bristle broom to scrub the surface.

**Note:** When the acid is applied, if the acid does not boil and bubble then there is still something on the deck.

8. After one person starts applying the acid mixture and scrubbing the deck another person should follow them using a 3000 psi pressure washer with the nozzle 3-4 inches off the deck to wash the acid off.
9. After the acid is washed off the deck, an additional pressure wash should be given. This time hold the pressure washer nozzle 1 foot from the deck surface.

**REMEMBER:** Do not neutralize the deck with neutralizers such as TSP or Baking Soda as the Kool Deck material will not bond to them.

10. Before the application of the PTA Bonding Agent the deck must be kept wet for a period of at least one (1) hour prior to using PTA.
11. Minor repairs such as damaged edges and/or depressions and holes, should be made at this time. Repair should be damp but without standing water. Brush PTA only into the area to be repaired. Using a rubber float as an applicator, pack holes and depressions with the overlay mixture in a thick enough consistency to avoid craze cracking.

### MIX & COAT THE SURFACE WITH THE PTA BONDING AGENT

REMEMBER: Before the application of the PTA Bonding Agent the deck must be kept wet for a period of at least one (1) hour prior to using PTA.

Mixing Formula – Follow carefully

- 1 Carton of PTA
- 1.3 Gallons (5 L) water



1. Place 0.5 gallon (2 L) of water in a 5 gallon bucket and add PTA; mix for two minutes with a drill and a rectangular mixing blade. Let mixture rest for three minutes.
2. Add remaining 0.8 gallon (3 L) of water and blend for three additional minutes until proper consistency is obtained.
3. When mixed with water, PTA should have the consistency of milk. Additional water can be added to maintain consistency.

### APPLICATION OF PTA INSTRUCTIONS

1. Pour PTA onto deck and use a broom to scrub PTA onto the entire surface (including the repaired areas). Be sure to cover surface completely.

**VERY IMPORTANT: DO NOT ALLOW PTA TO DRY BEFORE THE KOOL DECK MATERIAL IS APPLIED.**

2. Brush away all excess PTA. Base concrete should be visible through the PTA (thin coat is best).

### MIXING KEYSTONE KOOL DECK (Follow Carefully)

The Formula:

- 1 Unit Keystone Kool Deck
- 1 Bag White Cement (94 lbs.)
- 10 Gallons size 20 mesh marble sand (130 lbs.)
- 8 Gallons water

IMPORTANT: A paddle type mixer is necessary for a thorough, uniform blend.

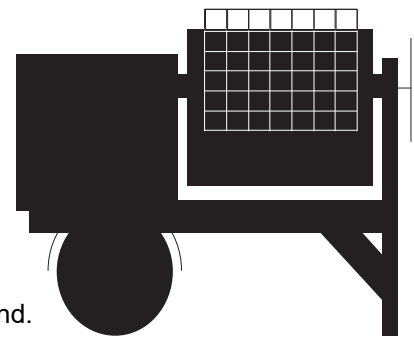

1. Deposit the marble sand into mixer; add just enough water to dampen the sand (1 gallon).
2. Add one Kool Deck unit. Allow this to mix for at least two minutes.
3. Add water (4 gallons) and white cement simultaneously. Allow this stiff paste to turn for three minutes.
4. Add additional water (3 gallons) until the mixture is of a “milky” consistency. If necessary, slightly more water should be added to achieve a thin, milky mixture. Use a viscosity cup to help obtain proper consistency.

### SPLASHING THE KEYSTONE KOOL DECK MIXTURE

1. Pour the mix from the mixer into a five gallon bucket.
2. Begin applying. Dip the dash brush into the mix covering the full length of the bristles and start splashing the mixture. If necessary, additional water should be added to the Keystone Kool Deck mixture so the material will rain from the brush and have a creamy appearance when splashed.



The best texture is achieved by raising the brush high and moving the hand forward, snapping back with the wrist. This motion causes the mix to rain from the brush and gives an even, uniform texture.

3. Splash on the mixture in even, straight, side by side rows, being sure to overlap so as not to leave any holidays.
4. Resplash the deck just before the first application has lost its water glaze. When applying a light second splash, allow the Kool Deck Elite mixture to rain down from the Dash Brush. The second splashing will drive the Kool Deck Elite surface into high peaks for good texture. The high texture produced by the second splash is necessary to allow trowelling time and to give a better pattern. Final material should be 1/8" total thickness.

### Trowelling THE KEYSTONE KOOL DECK® SURFACE

1. Begin to trowel as the water glaze leaves the deck. The pattern is set with the first trowel pass. The trowel must be held perfectly flat with a light hand. (The ideal tool is a Mortex Pattern Blade or a worn, cupped trowel)
2. The second trowelling must follow immediately behind the first. With the trowel held flat, feel for uneven surface, leveling it as you go.
3. A last pass may be necessary to bring the deck into a uniformly dense and color-fast deck surface. The finished deck should reveal approximately a 40% smooth and a 60% void surface. This prevents craze cracking since the knolls may expand and contract from the voids.

**Note:** Keystone Kool Deck can NOT be applied with Hopper Gun. The material will clog the hopper. A normal hopper will separate the sand and cement and the Kool Deck will not adhere properly.

Trowel as previously described.

### CURE WITH PLASTIC

**VERY IMPORTANT:** Immediately after final trowelling, cover area with Visqueen (aka Polyethylene Plastic) 2 mil. clear in color and leave covered for precisely two (2) days. Cover the areas immediately with plastic after trowelling. Do not wait until you have completed the entire job before covering with plastic. Weight the plastic down with sand so that air cannot circulate under the plastic and dry out the deck. Do not leave covered for more than two (2) days. If the deck surface exhibits white growths when the plastic is removed, wash the surface with water immediately. Use a stiff bristle nylon brush to scrub the surface. During the next 28 days, the deck surface should be washed frequently.

### COMPLETION OF WORK

Remove tape masking from surrounds, joints and drains, clean up around the job site and you are finished.

# PTA® Bonding Agent - For bonding Kool Deck Elite or Keystone Kool Deck to Existing Concrete

PTA Bonding Agent is a cement based bonder used to bond Kool Deck Elite, Keystone Kool Deck or Designer Colors to existing concrete. PTA should not be mixed with the overlay or reapplied multiple times, making it ideal for use where a thin cementitious overlay will be applied to existing concrete.

- A bonder with the same chemical and physical properties as the base concrete.
- Eliminates thermal stress caused by dissimilar materials making it durable under freeze / thaw conditions.
- Gray in color making it easy to verify coverage.
- Creates uniformity in the set rate of the overlay.



**Note:** PTA cannot be used with Solement or Systex Polymer Deck System.

Product Detail	Description
Coverage	One carton mixed properly covers 350 ft <sup>2</sup> (32.5 m <sup>2</sup> )
Contents	Available by the carton.
Ctn Measurements	7" x 7" x 12.5" (18 cm x 18 cm 32 cm)
Weight	20 lbs (9.07 kg)
Shipping Information	UPS, FedEx, Freight Truck, Ocean or Air

Catalog Item #	Description
KPTA	PTA - Bonding Agent

## PTA BONDING SYSTEM TECHNICAL INFORMATION

**PRODUCT DESCRIPTION:** PTA is a powdered cement based bonder. The fine particle size makes it ideal for use when a thin cementitious overlay will be applied over existing concrete.

**INTENDED USE:** PTA is used to bond KOOL DECK ELITE, KEYSTONE KOOL DECK or DESIGNER COLORS to existing concrete such as patios, walkways, courtyards, entry ways and swimming pool decks.

**COMPOSITION & MATERIALS:** PTA is composed of white cement, limestone and less than three percent organics. PTA is manufactured to exact quality control standards and maintains uniformity and performance.

**LIMITATIONS:** PTA must be stored in a dry place, as exposure to moisture will render it useless. In warm climates, extreme care should be taken if installation is to take place when temperatures are expected to exceed 95°F (35°C.) This is due to the necessity of the overlay to cure after application. In freeze-thaw climates, the finished application should be protected against frost and other severe conditions, for a period of 28 days. Caution: Do not use PTA® with the SYSTEX® Polymer Concrete Deck System or Solement.

### APPLICABLE STANDARDS

ASTM C1041-85 (30 Deg. Angle Shear Test) Standards when applied in accordance with Mortex instructions are as follows: Tests average 21,600 lbs. on a 3-inch core (1820 psi).

**COLOR:** PTA is light gray in color.

**WEATHER RESISTANCE:** PTA has excellent weatherability. A 28 day cure period assures excellent bond strength. The harder the surface, the less moisture it will accept, leaving it less susceptible to damage from freeze/thaw cycles.

# Kool Deck® Repair Kits

Mortex Kool Deck Repair Kits are a reliable solution for an unexpected problem. They are specially designed for ease of application and are a quick and easy way to complete a small repair. Each Repair Kit contains enough Bonder and Texture Material to cover 6 square feet.

- A quick way to complete small repairs.
- Pre-mixed for your convenience.
- Cost effective by mixing only what you need.
- Made with naturally occurring mineral compounds.



Product Detail	Description
Coverage	6 ft <sup>2</sup> per carton (0.557 m <sup>2</sup> )
Contents	Kool Deck Pre-Mix, PTA Bonding Agent, Repair Kit Applicator, Plastic
Ctn Measurements	7" x 7" x 9.5" (17 cm x 17 cm x 24 cm)
Weight	6 lbs (2.72 kg)
Shipping Information	UPS, FedEx, Freight Truck, Ocean or Air

Catalog Item #	Description
KXRKAB	Repair Kit Pre-Mix - Adobe Buff
KXRKAQ	Repair Kit Pre-Mix - Aqua
KXRKAG	Repair Kit Pre-Mix - Aztec Gold
KXRKBG	Repair Kit Pre-Mix - Birch Gray
KXRKCP	Repair Kit Pre-Mix - Coral Peach
DCXRKM	Repair Kit Pre-Mix - Mauve
KXRKRP	Repair Kit Pre-Mix - Rose Pink
KXRKSB	Repair Kit Pre-Mix - Sand Buff
KXRKST	Repair Kit Pre Mix - Sedona Tan
DCXRKT5	Repair Kit Pre-Mix - T-5
DCXRKTC	Repair Kit Pre-Mix - Terra Cotta
KXRKWH	Repair Kit Pre-Mix - White

## APPLICATION INSTRUCTIONS

### NECESSARY SUPPLIES

- Trowel
- Sponge or Towel
- Bucket
- Stirring Drill
- Sand

**COVERAGE:** Approximately 6 ft<sup>2</sup>

### SURFACE REQUIREMENTS

- The area being patched must be free of loose and deteriorated concrete.
- The surface must also be free of organic contamination.
- Before acid etching, soak not only the area being patched, but the surrounding deck with water.
- Use a solution of 1 part Muriatic acid to 1 part water. Confine the acid to the area being patched. When the surface is free of organics the solution will boil vigorously on contact.
- Until you have thoroughly scrubbed and rinsed the deck of the cement residue created by acid, never allow the deck to dry.
- Keep the area being patched completely wet until you're ready to apply the PTA bonder.

# Repair Kit Instructions

## APPLICATION INSTRUCTIONS CONTINUED

### MIXING PTA® BONDER

**Note:** DO NOT INTERMIX TOGETHER THE PTA BONDER AND KOOL DECK MATERIAL!

Mixing Ratio: 2 parts PTA to 1 part water.

- Put half of the necessary water and all of the PTA powder into a quart pail. Stir vigorously for 2 minutes.
- Allow mixture to stand for 3 minutes.
- After a 3 minute waiting period add the remaining half of water and mix thoroughly. During the 3 minute waiting period, mix the Keystone Kool Deck.

### MIXING KEYSTONE KOOL DECK®

- While mixing, slowly add 24 oz. (710 ml.) of water to the pail containing the premixed Keystone Kool Deck.
- Mix briskly until the Kool Deck material is well blended and smooth.

### COAT WITH PTA

- At this time the patch area must be thoroughly soaked with water then blot up any surface water.
- Use the applicator to “scrub” on a thin coat of the PTA bonder.
- Remove any PTA from the surrounding Kool Deck material with a sponge.

### COAT WITH KOOL DECK MATERIAL

- Rinse the PTA from the applicator. DO NOT Intermix PTA and Kool Deck.
- Begin the covering process by splashing Kool Deck material into the PTA. DO NOT let the PTA dry before applying the Kool Deck material.
- Before the Kool Deck loses its water glaze, resplash using just a small amount of Kool Deck in the applicator to produce high peaks.
- While you are waiting for the Kool Deck to become ready for trowelling, clean off over-splash from the surrounding deck. Use a wet sponge.

### TROWELLING

- When the water sheen begins to leave the Kool Deck material, start the trowelling process.
- Use only enough pressure to flatten the high points on the first pass.
- After a few minutes make a second pass with the trowel, using enough pressure to make the size and surface condition of the flats match the surroundings.
- Be sure to clean off any unwanted Kool Deck or PTA material at this time, cleaning later may be impossible.

### CURE WITH PLASTIC

VERY IMPORTANT: Immediately after final trowelling, cover area with Visqueen, 2 mil. clear and leave covered for precisely two (2) days. Cover the areas immediately with plastic after trowelling. Do not wait until you have completed the entire job before covering with plastic. Weight the plastic down with sand so that air cannot circulate under the plastic and dry out the deck. Do not leave covered for more than two (2) days. If the deck surface exhibits white growths when the plastic is removed, wash the surface with water immediately. Use a stiff bristle nylon brush to scrub the surface. During the next 28 days, the deck surface should be washed frequently to improve its strength.

# System<sup>®</sup> Deck Paint

System Deck Paint is formulated to provide a tough, durable, breathing film for the protection of previously painted, unpainted or textured concrete pool decks and walking surfaces. System paint will resist the effects of weather, water, abrasion, and pool chemicals. Available in a variety of flat finish colors, System paint coordinates perfectly with other Mortex product colors and enhances the beauty of any walkway, deck or backyard pool area.

- Can be applied to a damp surface; in fact, water helps the paint cure. In extremely dry areas, the deck should be misted with cool water prior to painting.
- Acrylic polymer is extremely sun fast and resistant to the sun's UV rays.
- Acrylic is tough, abrasion resistant and scrubbable.
- Can apply two coats in one day, only two hours apart.



**IMPORTANT: Does NOT provide cooling properties. When applied to your Kool Deck<sup>®</sup>, Solement, or concrete surface, the area will become hotter and slicker.**

Product Detail	Description
Coverage	125 - 150 ft <sup>2</sup> per gallon on bare, sandblasted or rough surfaces (3.3 - 4 m <sup>2</sup> ) 250 - 300 ft <sup>2</sup> per gallon on recoats (23.23 m <sup>2</sup> x 27.87 m <sup>2</sup> )
Contents	4 - 1 gallon units
Ctn Measurements	2 boxes that are each: 17" x 9" x 10" or 4 boxes that are each: 9" x 9" x 10"
Weight	12 lbs (5.44 kg) per gallon
Shipping Information	UPS, FedEx, Freight Truck, Ocean, Air

Catalog Item #	Description
PXPAD	System Deck Paint - Almond
PXPCY	System Deck Paint - Clay
PXPGD	System Deck Paint - Gold
PXPGY	System Deck Paint - Grey
PXPIY	System Deck Paint - Ivory
PXPMT	System Deck Paint - Malt
PXPPH	System Deck Paint - Peach
PXPRC	System Deck Paint - Rustic
PXPTN	System Deck Paint - Tan
PXPTE	System Deck Paint - Taupe

## Kool Deck<sup>®</sup> Overlay Color Match Chart

If you have an existing Kool Deck overlay, use this chart to find the corresponding paint color.

Paint .....	Kool Deck
Clay .....	Terra Cotta
Gold .....	Aztec Gold
Grey .....	Birch Grey
Peach .....	Coral Peach
Rustic .....	Sedona Tan
Tan .....	Sand Buff / Adobe Buff
Taupe .....	T-5

Keep in mind that the Deck Paint colors will not match exactly to your existing Kool Deck surface. System Deck Paint does NOT provide cooling properties and will make the surface hotter and slicker.



# Systemx® Deck Paint Instructions

## NECESSARY TOOLS

- 3/4" Nap Rollers
- Paint brushes for detailing
- Granular dishwasher detergent or Mortex Commercial Cleaner
- High Pressure Washer
- Mechanical mixer (this can be a paddle attachment to a power drill)

## OPTIONAL TOOLS

- 5 gallon bucket

## COVERAGE

- 125-150 sq. ft. on bare, sandblasted or rough surfaces
- 250-300 sq. ft. on re-coats

Coverage and the number of coats will vary depending on porosity and texture of the surface. Care should be taken not to apply too much paint. Applying too much paint will require longer drying times prior to allowing traffic. Thinning is not required.

**Note:** It is best to apply two thin coats opposed to one thick coat.

## SURFACE PREPARATION

The keys to a successful Systemx Deck Paint job are proper Surface Preparation and Correct Application. By following these simple steps, you're ensuring a virtually maintenance-free paint surface on your pool, walkway or deck.

**Step 1:** The area to be painted should be tested for integrity and soundness. Water blast the surface to remove any loose paint or dirt.

**Step 2:** Scrub the entire deck with granular dishwasher detergent or Mortex Commercial Cleaner. The deck should be completely free of dirt, oils, loose or peeling paint and chalk.

**Step 3:** High pressure wash the surface.

**Step 4:** Allow the deck to dry completely. In extremely dry areas the deck can be slightly damp, but with no puddles.

## MIXING THE PAINT

Systemx Deck Paint is self-priming; no other type of primer is recommended or should be used.

Mechanically mix the paint to achieve uniform consistency and color. If you are using more than one (1) gallon of paint at a time, it is necessary to intermix and mechanically mix several gallons together.

**Step 5:** Use not more than a 3/4" nap roller. Apply at the recommended coverage rate.

**IMPORTANT:** Do not paint when rain is imminent.

**Note:** Surface temperature should be at least 50° F. Ideal air temperatures for application are between 50-85° F. Not intended for an immersion surface or in areas subject to vehicular traffic. Not recommended for wood decks. New concrete must be cured a minimum of 28 days.



# Protect - A - Deck™

Mortex Protect-A-Deck™ is the product you need to shield mineral surfaces against the harmful effects of moisture and extreme temperature change. Protect-A-Deck can be used on Kool Deck Elite, Keystone Kool Deck, Designer Colors, Gypsum, Solement, Stucco or Brick.

- Curbs deteriorating effect of water and salts on concrete with durable water repellency (5 to 10 years).
- Reduces efflorescence.
- Chemically attaches to any mineral surface and bridges hairline cracks.
- Apply with a construction sprayer.
- Does not affect color of sprayed surface and will not change surface texture.
- Solvent-Free Silicone Siloxane.
- Not intended for use on Systemex.



Product Detail	Description
Coverage	1600 - 2400 ft <sup>2</sup> per gallon (148-223 m <sup>2</sup> )
Contents	1 gallon (3.79 L)
Ctn Measurements	12.75" x 12.75" x 12.65" (32.4 cm x 32.4 cm x 31.7 cm)
Weight	10 lbs (4.5 kg)
Shipping Information	UPS, FedEx, Freight Truck, Ocean or Air

Catalog Item #	Description
KPAD	Protect-A-Deck

## INSTRUCTIONS

### SURFACE REQUIREMENTS

- Concrete, rock or cementitious surface (including Mortex overlays, not including Systemex) must be a minimum of 28 days old before applying Protect-A-Deck.
- Clean, dry and free from stains
- Temperature at time of application should be between 40° and 95°F (4° and 35°C)
- Temperature for the next 24 hours should also remain within the range of 40° to 95°F

### MIXING

Mix only what you need. Mix 1 part Protect-A-Deck to 15 parts water by volume. The mixed solution will have a usable life span of 3 hours.

**Note:** Always keep the original container closed, as exposure to moisture starts a chemical reaction much like the hydration of cement. Once Protect-A-Deck hydrates, it will not bond to cement.

### APPLICATION

Use a construction sprayer to apply the solution. Apply 2 to 3 coats to the surface. Wet surface thoroughly with solution but do not create puddles. Allow time between coats so that the solution can penetrate the surface, but do not allow the surface to dry between coats. Coverage varies depending on number of coats, porosity of surface and temperature of surface at the time of application. The warmer the temperature, the more material you will use.

**Caution:** Wear goggles and rubber gloves when handling. For cleanup, wash skin and equipment with soapy water.

**Note:** For maximum repellency, a three (3) day cure period, void of rain, is essential.

# Coping Mask™

Coping Mask™ is a fast, simple, brush on coating for the protection of coping and other non-porous surfaces during the concrete pour. Coping Mask prevents the bonding of cement and cement based overlays, such as Keystone Kool Deck, Kool Deck Elite or Designer Color surfaces without damaging the surrounding concrete.

- Eliminates, in some instances, the use of paper or plastic coverings
- Deters the staining caused by concrete, mud, soaps and shoe marks
- Applies easily with a large paint brush
- Removes quickly with a stiff bristled brush



Product Detail	Description
Coverage	Varies with application
Contents	5 gallon bucket (18.9 L)
Ctn Measurements	12" diameter x 15" H (30.5 cm x 38 cm)
Weight	40 lbs (18.1 kg)
Shipping Information	UPS, FedEx, Freight Truck, Ocean or Air

Catalog Item #	Description
KCM	Coping Mask

## INSTRUCTIONS:

Apply with a large paint brush and remove with a stiff bristled brush and a garden hose.



# Commercial Cleaner

Expose the original beauty of concrete decking when you clean with Commercial Cleaner. It is low in cost, simple to use and easy to store. Commercial Cleaner is the strongest cleaner you can safely use on your Kool Deck Elite, Keystone Kool Deck or Designer Color surfaces.

- Can be used as a pre-scrubbing spot cleaner.
- Lifts out imbedded grime with bubbling cleaning action.
- Simple to use on dirt and grime, leaf stains, rust stains or fertilizer stains.

**CAUTION:** This product contains acid. Protect eyes with goggles. Wear protective clothing including rubber boots and rubber gloves.



Product Detail	Description
Coverage	1 cup cleans approximately 100 ft <sup>2</sup> (9.29 m <sup>2</sup> ) 1 gallon container cleans 1600 ft <sup>2</sup>
Contents	Available in one gallon dry mixture
Ctn Measurements	9" x 9" x 8.5" bucket (23 cm x 23 cm x 22 cm)
Weight	9 lbs (4.05 kg)
Shipping Information	UPS, FedEx, Freight Truck, Ocean or Air

Catalog Item #	Description
KCCOM	Commercial Cleaner



# Commercial Cleaner Instructions

## Excellent for cleaning Keystone Kool Deck, Kool Deck Elite, Designer Colors and Solement.

- Spot or general cleaning
- Dirt and grime
- Leaf stains
- Rust stains
- Fertilizer stains
- Mineral deposits
- Easy to store

**CAUTION:** This product contains acid. Protect eyes with goggles. Wear protective clothing including rubber boots and rubber gloves.

**Cleaning is a 2 part process. Part 1 must always be followed by Part 2**

**PART 1:** Mixture for heavily soiled or stained areas.

Combine: 1 cup cleaner & 1 gallon water

Instructions: First wet the stain and sufficient area around it so that the cleaner does not come in contact with dry cement. Pour small amount of solution on the stain. Scrub vigorously for 30 seconds with a stiff nylon bristle brush. Rinse immediately. Repeat the process 2-3 times if necessary.

**PART 2:** Mixture for the cleaning of the entire surface of the deck.

Combine: 1 cup cleaner & 5 gallons water

(This should clean approximately 100 sq feet per gallon.)

Instructions: Wet the deck thoroughly with water and then pour small amounts of the solution over the deck. Use a large nylon bristle broom to scrub the solution over the deck ensuring to scrub the entire deck. Make sure to keep the entire surface wet at all times. After scrubbing, rinse the deck with water from a garden hose. This process may need to be repeated at least 1-2 more times.

**Note:** If any of the solution should run or splash onto the already scrubbed area be sure to scrub and rinse again. Failure to do this will leave a residue (white film).

### EXPERIENCED CONTRACTORS ONLY:

In some cases a more extreme method of cleaning may need to be used. Mortex recommends this method to contractors only. The contractor must also be experienced in using Heavy Duty Floor Buffers. After using the procedure in Part 1, follow the next steps. Combine 1 cup of cleaner and 5 gallons of water. Wet the deck thoroughly with water and pour small amounts of solution on the deck. Use a 3M stripping pad (medium duty) and a heavy duty floor buffer to spread the cleaner and scrub the deck. Run the buffer over the deck making even passes with a 1/3 overlap. Scrub the entire surface keeping the deck wet at all times. Rinse the deck. Stay 2-3 feet behind the scrubber and wash the deck thoroughly with water.

**Note:** If any of the solution should run or splash onto the already scrubbed area be sure to scrub and rinse again. Failure to do this will leave a residue (white film).

**Note:** This product CANNOT be used on Systemex or painted surfaces.

**WARNING:** This product can attack cement.  
Overuse can cause damage to decorative concrete overlays.

# Tools & Accessories

## DASH BRUSH

To achieve the quality surface texture your client is looking for, Mortex's Dash Brush is the perfect tool for applications of Keystone Kool Deck, Kool Deck Elite or Designer Colors.

- Made with high quality materials to last.
- Cleans up easily.

Product Detail	Description
Contents	Sold individually or by the carton
Carton Measurements	16" x 16" x 11" (41 cm x 41 cm x 28 cm)
Weight	13 lbs (5.4 kg) per carton
Shipping Information	UPS, FedEx, Freight Truck, Ocean or Air

Catalog Item #	Description
KXDB	Dash Brush (12 carton)



## VISCOSITY CUP

Mortex's Viscosity Cup helps the contractor determine the correct amount of water for Kool Deck Elite, Keystone Kool Deck and Designer Colors. To use a Viscosity Cup, tape handle to a yardstick to keep hands and arms out of the mixer or bucket. Stop mixer and fill cup full with material. Lift cup out of material and start clock. The Viscosity Cup should drain in 17 seconds for best results on flat surfaces of Kool Deck Elite, Keystone Kool Deck and Designer Colors.

- Helpful in adjusting the consistency of material for a proper deck finish.

Product Detail	Description
Contents	Sold individually
Carton Measurements	Varies
Weight	Varies
Shipping Information	UPS, FedEx, Freight Truck, Ocean or Air

Catalog Item #	Description
KXVCUP	Viscosity Cup



## PATTERN BLADE™

A quality surface texture requires a good pattern to be initially set. It helps make small work of lightly setting the pattern on the splashed deck.

- Made with telescoping handle for reaching greater distances.
- 6 foot handle extends to 12 feet.

Product Detail	Description
Contents	Sold individually
Carton Measurements	With handle: 3" x 6" x 79" (7cm x 15cm x 200.7cm) Without handle: 3"x6"x25" (7cm x 15cm x 63.5cm)
Weight	With handle: 6 lbs (2.7 kg) Without handle: 2 lbs (0.9 kg)
Shipping Information	UPS, FedEx, Freight Truck, Ocean or Air

Catalog Item #	Description
TPB	Pattern Blade with Handle
TPBNH	Pattern Blade - No Handle
TPBB	Pattern Blade Replacement Bracket



# Solement™ Hybrid Cement Overlay

SOLEMENT hybrid cement overlay is the only polymerized concrete deck overlay that can be used any concrete, new or existing. SOLEMENT is simple system that provides a beautiful texture to pool decks, patios and other concrete areas. This product is highly unique without separate base & top coating extras to achieve the adhesion and durability.



- No Base or Top Coat! Simply clean deck, apply to wet deck and walk away.
- Can be applied to fresh concrete or the next day - No waiting for cure time.
- Uses simple, integral Color Unit packs, just like Kool Deck Elite.
- Just add water - no fancy, complicated or expensive polymers to mix.
- Wet applied system means no waiting for concrete or other components to dry.

Product Detail	Description
Coverage	A properly mixed bag should cover a minimum of 65 ft <sup>2</sup> (6 m <sup>2</sup> )
Contents	1 - 50 lb. Bag
Bag Measurements	14" x 19" x 4 1/2" (35.6 cm x 48.3 cm x 11.4 cm)
Weight	50 lbs (22.68 kg) - 52 lbs boxed
Shipping Information	UPS, FedEx, Freight Truck, Ocean or Air

Catalog Item #	Description
SOLE	Solement - 50# Bag (White)
SOLEGV	Globe Valve Assembly for Air Reduction

For available color options, see page four (4) for Color Units.

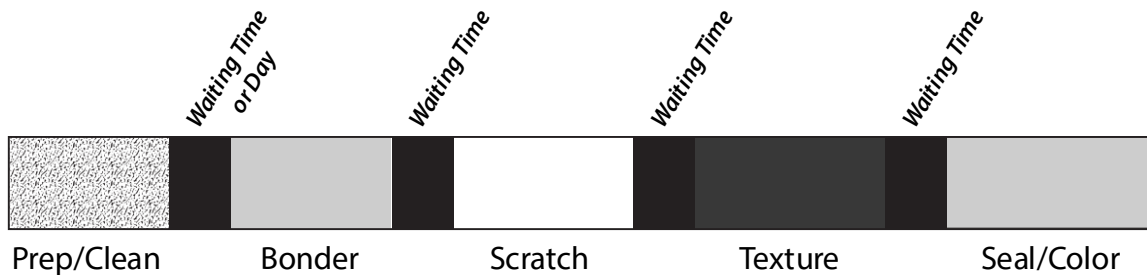

## Conventional Polymer Overlay Process

**OR**



Prep/Clean      Solement

## The Solement Advantage

**Learn more now!**

**Instruction  
Video**  
Scan QR Code



# Solement™ Hybrid Cement Overlay

## PRODUCT INFORMATION

SOLEMENT™ is a unique, color integral polymer overlay for both new and existing concrete.

## INTENDED USE

SOLEMENT is a polymer cement overlay for use on walkways, patios, courtyards and swimming pool decks. It can be used on new and existing concrete surfaces. The SOLEMENT surface is more skid-resistant than most polymer overlay products with an extensive color palette to assist in creating a beautiful look to otherwise drab or worn concrete.

## COMPOSITION AND MATERIALS

SOLEMENT is composed of a proprietary mixture of cement, limestone, polymer(s), organic and inorganic substances, and is manufactured with precise quality control standards, to ensure uniformity.

## LIMITATIONS

SOLEMENT should not be mixed with any other ingredient except those specified in the instructions. Follow mixing instructions to ensure uniform color. SOLEMENT material should be stored in a dry place.

## APPLICABLE STANDARDS

SOLEMENT performance when tested in accordance with ASTM C109;

Compressive Strength: 2-inch cube specimens (50 mm)

- 1) 3018 pounds per square inch after 7 days curing time; within two standard deviations.
- 2) 3773 pounds per square inch after 14 days curing time; within two standard deviations.
- 3) 4534 pounds per square inch after 28 days curing time; within two standard deviations.

## COLORS

SOLEMENT is available in eleven standard colors. Four Designer Colors are available, and are warmer to the touch due to their darker shade. All colors are approximately represented on Mortex's color chart.

## WEATHER RESISTANCE

SOLEMENT has excellent weatherability. SOLEMENT will cure to a density and hardness that absorbs less water than standard concrete, giving it good freeze/thaw durability. Unlike conventional polymers, surface deterioration from thermal stress does not occur because the coefficient of expansion and contraction are the same for both base and overlay. All of the ingredients in SOLEMENT are unaffected by ozone or UV radiation as well as pool chemicals and chlorine.

## WARRANTY

Information contained herein is to our best knowledge, true and accurate but all recommendations or suggestions are made without guarantee. Since the conditions, usage and application of our products are beyond our control, Mortex disclaims any liability incurred in connection with the use of our products and information contained herein. No person is authorized to make any statement or recommendation not contained herein, and any such statement or recommendation so made shall not bind the company. Furthermore, nothing contained herein shall be construed as a recommendation to use any product, and no license implied or in fact is granted herein. Mortex further reserves the right to change specifications of products described herein without notice.

# Solement™ Hybrid Cement Overlay

## NECESSARY TOOLS

- Hopper Gun, with 3/8" orifice
- Air Compressor, with a minimum of 2.4 CFM at 90 psi and a four (4) gallon capacity or more
- Square Blade Mixing Paddle
- 1/2" Heavy Duty Drill
- Several 5 or 6.5 gallon buckets
- Sponges
- Steel Finishing trowels (round not square)

## REQUIRED MATERIALS

- 1 Color-Unit™ pack
- 1 - 50 pound Bag of Solement

## COVERAGE

A 50 lb. bag of Solement will cover approximately 100 ft<sup>2</sup> with medium texture. One Color-Unit pack is required for every bag of Solement.

## SURFACE PREPARATION - EXISTING CONCRETE

1. Mask off adjoining areas to prevent damage and clean up problems. Also, tape off joints and drains.
2. Apply to a level, clean, sound, and patched concrete surface.
3. Scrub muriatic acid over the damp deck, followed immediately by a high-pressure wash. For the best bond adhesion, do not apply a neutralizer such as TSP or Baking Soda after acid washing.

## SURFACE PREPARATION - NEW CONCRETE

Solement can be applied same-day as fresh concrete. Follow technical requirements for Kool Deck found on page eight and nine of this catalog for proper substrate composition, handling and placement.

## MIXING INSTRUCTIONS

1. Pour one (1) gallon (3.79 L) of Water into Mixing Bucket.
2. Mix one (1) entire Color-Unit pack into Mixing water, using the heavy-duty drill with paddle blade.
3. Dump entire 50 lb. bag of Solement into colored water while mixing.
4. Mix for three (3) minutes into an even colored, thick paste. Allow mix to stand for two (2) minutes.
5. Restart mixing. Slowly add up to an additional one half gallon (1.9 L) of water to the mix.

## APPLICATION INSTRUCTIONS

1. Mist hopper with water, empty, and then add Solement material.
2. Spray enough material to be troweled into concrete as a thin, full coverage skim coat.
3. Adjust hopper to spray properly with a creamy appearance.
4. For hoppers spraying a larger texture, a medium skim coat and single texture spray pass is possible.
5. With skim coat still wet, spray for texture. If needed, follow with a final texture pass.
6. When water glaze leaves the surface, set a pattern in a single pass with the trowel held perfectly flat with a light hand. Simply establish flats, then quit.
7. Use a wet sponge to clean excess material from trowel.
8. For existing concrete only, when deck is finished and fully dried to a visible color change, mist deck with water to aid curing.
9. Misting before the deck is fully dry will cause efflorescence.
10. Finally, give deck owner a Solement Care Card to help them with their new, beautiful deck.



# System<sup>®</sup> Polymer Deck System

SYSTEX polymer concrete deck system leads the industry in quality and ease of use. System is a three step system that provides a beautiful complement to new or existing pool decks, patios and other concrete decks. Homeowners and businesses can choose from an array of attractive colors, and get polymer durability that stands up to wear and weather for years.

- Surface cleans up easily and is resistant to oil and grease stains better than plain concrete.
- Has the durability to withstand high heat and freeze/thaw conditions.
- Texture gives a great look to otherwise drab or worn concrete.
- System can be used with stencil and other decorative applications.



Product Detail	Description
Coverage	Bonder: Average of 1600 ft <sup>2</sup> per 5 gallon bucket (40 m <sup>2</sup> per 18.92 L) Texture: 125 ft <sup>2</sup> per 50 lb. bag (18.6 m <sup>2</sup> per 22.68 kg) Color: Average of 500 ft <sup>2</sup> per 5 gallon bucket (16.5 m <sup>2</sup> per 18.92 L)
Contents	Bonder: 5 gallon bucket (18.92 L) Texture: 50 lb.. bag (22.67 kg) available in Tan or Grey Color: 5 gallon bucket (18.92 L)
Ctn Measurements	Bonder: 12" Diameter x 15" height (30.5 cm x 38.1 cm x 38.1 cm) Texture: 21" x 11" x 6 1/2" (53.3 cm x 27.9 cm x 16.5 cm) Color: 12" diameter x 15" height (30.5 cm x 38.1 cm)
Weight	Bonder: 40 lbs per 5 gallon bucket (18.1 kg) Texture: 50 lbs. per bag (22.7 kg) Color: 60 lbs. per 5 gallon bucket (27.3 kg)
Shipping Information	UPS, FedEx, Freight Truck, Ocean or Air

Catalog Item #	Description
PSB	System Bonder
PSTG	System Texture - Grey
PSTT	System Texture - Tan
PSCAD	System Color - Almond
PSCCY	System Color - Clay
PSCGD	System Color - Gold
PSCGY	System Color - Grey
PSCIY	System Color - Ivory
PSCMT	System Color - Malt
PSCPH	System Color - Peach
PSCRC	System Color - Rustic
PSCTN	System Color - Tan
PSCTE	System Color - Taupe



# System<sup>®</sup> Technical Information

## PRODUCT INFORMATION

SYSTEX is a three-step polymer concrete deck system.

## INTENDED USE

SYSTEX is a polymer concrete overlay for use on walkways, patios, courtyards and swimming pool decks. It can be used on new and existing concrete surfaces. The SYSTEX surface is more resistant to oil and grease stains than plain concrete. The SYSTEX System offers an extensive color palette to assist in creating a personalized exterior design – a beautiful look to otherwise drab or worn concrete.

## COMPOSITION AND MATERIALS

SYSTEX is composed of a proprietary mixture of organic and inorganic substances. SYSTEX is manufactured with precise quality control standards, to ensure uniformity.

## LIMITATIONS

SYSTEX should not be mixed with any other ingredient except those specified in the instructions. None of the SYSTEX products are to be mixed together. These products should only be applied in the prescribed order. New concrete should cure for 28 days for best results. Unused SYSTEX bonder and color products are to be kept covered, keeping them from drying out. If the bonder or color dries out or freezes, it is not usable. SYSTEX texture should be stored in a dry place.

## APPLICABLE STANDARDS

SYSTEX performance when tested in accordance with ASTM C666-84;

Rapid Freezing and Thawing: Advanced polymer chemistry gives SYSTEX a superior bonding agent that is capable of withstanding 200 freeze/thaw cycles.

## COLORS

SYSTEX is available in several standard colors. These colors are approximately represented on Mortex's color chart.

## WEATHER RESISTANCE

SYSTEX has good weatherability. SYSTEX cures to a density and hardness that absorbs less water than standard concrete, giving it good freeze/thaw durability. A SYSTEX application is unaffected by ozone or UV radiation. SYSTEX is also unaffected by pool water chemicals and chlorine.

## WARRANTY

Information contained herein is to our best knowledge, true and accurate but all recommendations or suggestions are made without guarantee. Since the conditions, usage and application of our products are beyond our control, Mortex disclaims any liability incurred in connection with the use of our products and information contained herein. No person is authorized to make any statement or recommendation not contained herein, and any such statement or recommendation so made shall not bind the company. Furthermore, nothing contained herein shall be construed as a recommendation to use any product, and no license implied or in fact is granted herein. Mortex further reserves the right to change specifications of products described herein without notice.

# System<sup>®</sup> Texture Instructions

## NECESSARY TOOLS

- Hopper Gun
- Air Compressor
- Square Blade Mixing Paddle
- ½" Heavy Duty Drill
- Several 5 or 6.5 gallon buckets
- Several 9" x ¾" nap rollers
- Heavy Duty paint rolling handle
- Sponges
- Steel Finishing trowels (round not square)
- Paint Brushes for detailing

## SURFACE PREPARATION

1. Mask off adjoining areas to prevent damage and clean up problems. Also, tape off joints and drains.
2. Apply to a clean, sound concrete surface. The length of cure depends on the severity of deck exposure (3 to 28 days).
3. If you patch cracks and holes, allow for adequate drying time.
4. Scrub muriatic acid over the damp deck, followed immediately by a high-pressure wash. For the best bond adhesion, Do not apply a neutralizer such as TSP or any other cleaning agent after acid washing.

## STEP ONE - BONDER APPLICATION

This product provides a bond between the concrete surface and the polymer texture. Do NOT mix the bonding agent with either the polymer texture material (SYSTEX Step 2) or the color coat (SYSTEX Step 3).

When the bonder is applied properly, you can expect coverage of 300 to 350 ft<sup>2</sup> per gal. (8 to 9 m<sup>2</sup> per liter) or 1600 ft<sup>2</sup> per 5 gallon bucket.

## BONDER APPLICATION

1. Stir Bonding Agent, if necessary, but do not add water. Cover bonding agent container when not in use. If it dries out, it is not rewettable or usable.
2. Apply Bonding Agent when the concrete's surface temperature is above 50 °F and below 90 °F (10°C to 32°C). Under high heat conditions, mist the concrete with water to lower its temperature, but do not apply the bonding agent on wet concrete. As a general rule, the warmer the surface, the faster the drying time.
3. Use a ¾" nap roller. Dip roller directly into container to apply.
4. Spread a thin, even coat. Use a V-shaped foam roller to work the bonder into crevices and joints.
5. Remove all excess bonding agent, especially from grooves and joints, before it dries.
6. If a spot is missed, it can be filled in, even after the total area is dry.
7. When the bonding agent is wet, it is a white color. When dry, it becomes clear.
8. The bonding agent must dry before it gets rained on.
9. You have up to 2 days to continue on with SYSTEX texture (Step 2)
10. Clean rollers with water. To make it easier to start and stop, keep rollers wet until ready for cleanup.

## STEP TWO - TEXTURE APPLICATION

This product is mixed with water, applied on top of the bonding agent and is troweled to result in a textured surface. Do NOT mix the polymer texture with the bonding agent or color coat.

When this product is applied properly, you can expect coverage of 65 to 200 ft<sup>2</sup> per 50 lb. bag. The average product usage is 125 ft<sup>2</sup> per bag.

## SURFACE PREPARATION

1. Apply this product only after the Bonding Agent has been applied, and has completely dried clear.
2. You must mask all adjoining areas(including joints & drains) to prevent damage and clean-up problems.
3. If there is any dirt or other material on the deck, hose it off. Do not power wash or use a leaf blower or a broom to clean surface.

# System<sup>®</sup> Texture Instructions

## MIXING

1. Pour 1/4 gallon of water into a clean 5 gallon bucket.
2. Place your square bade mixing paddle (attached to a drill) into the bucket.
3. Begin to add the 50 lbs of texture while mixing and adding 1/2 gallon more water. You may have to add more water to get a smooth consistency. Mix as a thick paste before adding water for final consistency.
4. Allow the mixture to stand for 2 minutes. Although the material will have appeared to setup, it is still fluid. The polymers in the mixture must have time to turn to a liquid or else a failure can occur.
5. Mix the material again for approximately one minute until it is the consistency of buttermilk.

## TEXTURE APPLICATION

1. Prepare a clean, texturing-type hopper gun. Set the 3/8" orifice and adjust the air to 17 psi..
2. Wet the hopper, fill it with the System Texture and begin spraying. Full coverage is not necessary, just a sufficient amount to produce an even "knockdown" pattern when troweled. (If you have experience applying Mortex KEYSTONE KOOL DECK<sup>®</sup>, you can also use a dash brush to apply the Polymer Texture.)

## TROWELLING

1. Use a 14" round-ended pool trowel. Have a wet sponge or rag with you at all times to wipe off excess Polymer Texture material as you trowel. A clean trowel will also allow a smoother finish.
2. Start to trowel as the water glaze leaves the material. If you wait too long before trowelling, it will be difficult to give the surface a smooth finish.
3. Establish a nice, even texture. Do not hard finish the surface like normal concrete. Simply establish the flats, then quit.
4. Clean up tools with water and a wire brush.

## STEP THREE - COLOR APPLICATION

This product is applied on top of the polymer texture to add color. Its polymer chemistry adds chemical and moisture protection to the surface. DO NOT mix the polymer color coat with the bonding agent (SYSTEM Step 1) or texture (Step 2). The color coat can be applied with paint rollers or through a paint sprayer. Use of a paint roller provides a stronger paint surface. When this product is applied properly, you can expect coverage of 600 sq feet per 5 gallon bucket.

## COLOR SEAL APPLICATION

1. The Texture must be almost, but not completely dry before applying the Color Coat. The surface should begin to have a splotchy, white and gray appearance. Best results occur when the Texture and Color Coat dry at the same time.
2. **IMPORTANT:** If you are using more than one bucket of material it is necessary to intermix and mechanically mix several buckets together. Do not dilute the Color Coat material with water.
3. Dip a 3/4" nap roller directly into the bucket and "paint" the surface with overlapping strokes, being careful to get the material deep into the texture. Use a V-shaped foam roller to work the coating into crevices and joints.
4. The warmer the temperature, the shorter the drying time.
5. Clean rollers with water.

## COMPLETION OF WORK

1. Remove tape masking from joints and drains, clean up around the job site, and you are finished.
2. Remind the deck owner to avoid traversing and placing furniture on the deck for a minimum of two weeks. The deck has to have time to harden and cure sufficiently to warrant general use.

## AFTER INSTALLATION

Restrict to light use for a minimum of three days. Placing of patio furniture, hard-soled shoes and heavy use of surface should be avoided for at least two weeks.

# Channel Rite™

Mortex has once again responded to the industry's needs with Channel Rite™. It is a two piece, linear, non-directional water channeling system. Due to its design and heavy wall construction, warping and bowing found in other drain is greatly reduced. Channel Rite's full two inch top provides greater water flow from the deck surface, and it's height allows for concrete shrinkage and proper placement despite the many different field installation applications.

- Convenient and versatile removable top
- Easily coupled with 1 1/2" PVC pipe
- Can be placed flush against wall or previous pour
- Linear bottom feet provide stabilization

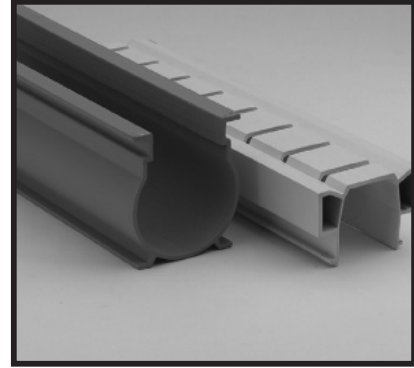

Product Detail	Description
Coverage	80 ft. per carton (24.4 m)
Contents	8 - 10 ft. lengths, 4 Couplers, 4 end caps (3.05 m)
Carton Measurements	129" x 6 3/4" x 7" (327.7 cm x 17.1 cm x 17.8 cm)
Weight	52 lbs (23.6 kg)
Shipping Information	Freight Truck, Ocean, or Air

Catalog Item #	Description
CRW	Channel Rite - White
CRT	Channel Rite - Tan
CRM	Channel Rite - Marble
CRG	Channel Rite - Gray
CRC	Channel Rite - Charcoal
CRTW	Channel Rite - White Top Only
CRTT	Channel Rite - Tan Top Only
CRTM	Channel Rite - Marble Top Only
CRTG	Channel Rite - Gray Top Only
CRTC	Channel Rite - Charcoal Top Only
CRB	Channel Rite - Base Only
CRX90T	Channel Rite - 90 degree Tan
CRX90G	Channel Rite - 90 degree Grey
CRX90W	Channel Rite - 90 degree White
CRX90C	Channel Rite - 90 degree Charcoal
CRX90M	Channel Rite - 90 degree Marble
CRX45T	Channel Rite - 45 degree Tan
CRX45G	Channel Rite - 45 Degree Grey
CRX45W	Channel Rite - 45 Degree White
CRX45C	Channel Rite - 45 Degree Charcoal
CRX45M	Channel Rite - 45 Degree Marble
CRXDS	Channel Rite - Down Spout
CRXES	Channel Rite - End Spout
CRXSS	Channel Rite - Straight Spout
CRXC	Channel Rite - 2" Coupler (6" piece of 1 1/2" PVC pipe)
CRXECT	Channel Rite - End Cap Tan
CRXECG	Channel Rite - End Cap Grey
CRXECW	Channel Rite - End Cap White
CRXECC	Channel Rite - End Cap Charcoal
CRXECM	Channel Rite - End Cap Marble

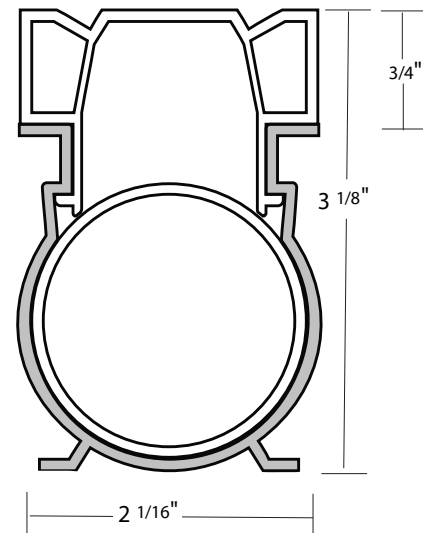

# Channel Rite Instructions

To join pieces together, use a 6" piece of 1.5" PVC pipe (coupler). Secure with PVC glue.



Make sure to join angles together with a coupler (6" piece of PVC).

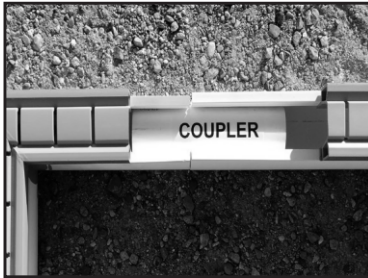

## Installation Instructions:

Grade the sub-soil sloping toward the Channel Rite. Assemble the Channel Rite tops and bottoms before installation. Metal or wood stakes can be used to position channel and be removed during pour. Use 1.5" PVC pipe to connect two pieces and to connect angles. Secure all connections with PVC glue.

End Cap - Secure with PVC glue.

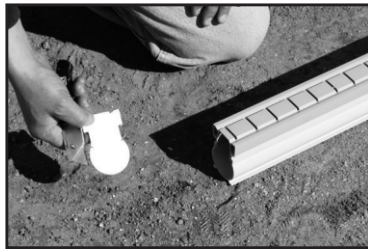

End Cap with PVC Coupler



## Tip For Added Strength:

During installation insert a short piece of 1.5" PVC into the base of the drain, at the center of the section. Make sure the top is completely down on base and locked into the bottom. This will assist the top portion of the drain to not lift after installation due to high heat expansion from pavers or shifting concrete in expansive soil.

# Drain Rite®

Drain Rite is a lineal, heavy-wall one piece contractual joint system for concrete crack control and water drainage. Drain Rite features obstruction free water flow, because it uses outside couplers. All extrusion and compounding is done in-house to assure the highest quality.

- Designed to set flush against walls and porches.
- Non-directional system requiring a minimum of fittings.
- Locked into the concrete by inside key ways that stop the flow of water to the subsoil.
- Used as a screed guide for concrete finisher.

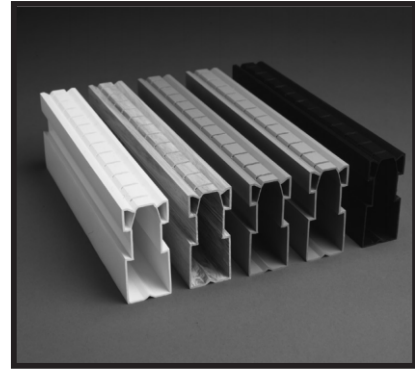

Product Detail	Description
----------------	-------------

Coverage	80 ft. per carton (24.4 m)
Contents	8 - 10 ft. lengths (3.05 m), 8 Couplers
Ctn Measurements	129" x 6 3/4" x 7" (327.7 cm x 17.1 cm x 17.8 cm)
Weight	43 lbs (19.5 kg)
Shipping Information	Freight Truck, Ocean or Air

Catalog Item #	Description
----------------	-------------

DRC	Drain Rite – Charcoal
DRG	Drain Rite – Gray
DRM	Drain Rite – Marble
DRT	Drain Rite – Tan
DRW	Drain Rite – White

## PRODUCT DESCRIPTION

DRAIN RITE is a heavy walled, one-piece PVC lineal drainage system that also acts as a full expansion and contraction joint.

## INTENDED USE

DRAIN RITE is used in horizontal concrete slabs when water accumulation is expected. It is a drainage system for foot traffic areas such as walkways, patios, courtyards and swimming pool decks. Inside key ways stop the flow of water to the subsoil and allow the drain to be set against walls and porches. Lengths and fittings are attached together using outside couplers keeping the water flow area free of obstructions. DOWN SPOUTS are used to drain the system completely and eliminate fungus growth. It can be used as a screed guide and is non-directional, requiring a minimum amount of fittings.

## COMPOSITION & MATERIALS

Mortex compounds its own PVC formulations for DRAIN RITE. To our polyvinyl chloride, we add acrylic impact modifiers for superior long-term exterior strength & Titanium dioxide to protect against the harmful effects of ultraviolet radiation. We use iron oxide pigments for coloring which does not fade.

## LIMITATIONS

DRAIN RITE should not be exposed to xylene based acrylic sealers for extended periods as shape and strength will be affected. DRAIN RITE should be stored indoors to keep the protective tape flexible and easy to remove. DRAIN RITE should be limited to pedestrian traffic areas.

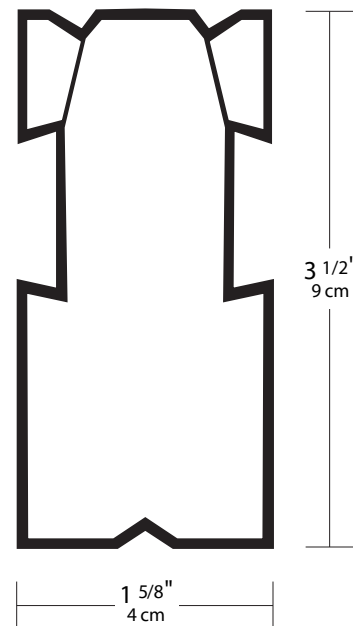

# Drain Rite® Instructions

## WEATHER RESISTANCE

DRAIN RITE has excellent weatherability and is virtually unaffected by chlorine and pool chemicals. Garner Impact Testing: After 1000 hours of weathering, DRAIN RITE did not show any significant change in impact resistance values. Under UVA 340 bulbs: Whiteness (L value) remained constant.

## FITTINGS

Fittings are sold and packaged separately. Available fittings are: 90°, 45°, TEE, CROSS, COUPLER, CLEAN-OUT-COVER, DOWN SPOUT, END CAP, END SPOUT, and STRAIGHT SPOUTS.

## GRADE/SITE SUGGESTIONS

Deck Slope 1/4" per 1' (.635 cm per 30.48 cm). Although DRAIN RITE can run horizontal end-to-end, a slope of 1/4" to 1/2" (.5 cm to 1.5 cm) for a 10' run (3.048 m) is advisable. Maximum distance between DOWN SPOUTS should be 28' (8.5 m). DOWN SPOUTS and END SPOUTS are 1 1/2" (3.81 cm) plastic pipe size.

## INSTALLATION

Grade the subsoil, sloping toward the drain location. In the path designated for the drain, drive short wood or steel stakes 3 feet apart, flush with the ground. Snap on nailing clips and couplers. Position the drain over the stakes. Align and nail to the tops of the stakes. When drain water is to be conducted away from the immediate area, DOWN SPOUTS are used. Maximum distance between Down Spouts should be 28" (8.5 m). Saw a 2" wide x 3/4" deep (5 cm x 2 cm) "V" notch in the bottom of the drain. Snap the Down Spout on the drain over the hole, then connect to 1 1/2" (3.82 cm) PVC pipe. An END SPOUT or STRAIGHT SPOUT may also be used to conduct water away from the area.

**Note:** PVC pipe glue can be used to secure and seal units together, or to attach DOWN SPOUTS, STRAIGHT SPOUTS and END SPOUTS.

## CAPACITY

DRAIN RITE available flow area is 3.94 in<sup>2</sup> (25.4 cm<sup>2</sup>). Capacity of a DOWN SPOUT is 27 gallons per minute (102.2 L). Water flow out the end of DRAIN RITE is 55 gallons per minute (208.2 L). 1" (2.54 cm) of rain per hour with a DOWN SPOUT placed every 28' (8.5 m) on a deck 8' (2.43 m) wide will constitute maximum flow.





# Drain Rite® Replacement Top

Drain Rite Replacement Top is an innovative and convenient way to repair and/or replace existing drains.

Product Detail	Description
Coverage	80 ft. per carton (24.38 m)
Contents	8 - 10 ft. lengths (3.05 m)
Ctn Measurements	5" x 5" x 120 1/2" (12.7 cm x 12.7 cm x 306 cm)
Weight	30 lbs (13.6 kg)
Shipping Information	Freight Truck, Ocean or Air

Catalog Item #	Description
DXRTC	Drain Rite Replacement Top - Charcoal
DXRTG	Drain Rite Replacement Top - Gray
DXRTM	Drain Rite Replacement Top - Marble
DXRTT	Drain Rite Replacement Top - Tan
DXRTW	Drain Rite Replacement Top - White

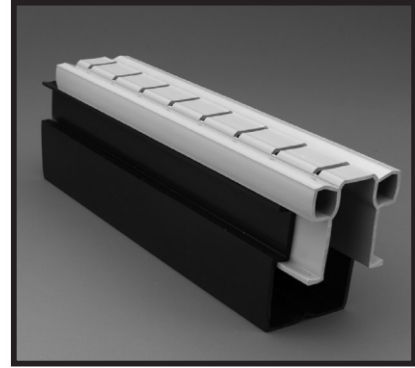

## NECESSARY TOOLS

- 3/8" & 1 1/2" or 2" Chisel
- Tin Snips or Saw
- Caulk

## INSTALLATION

- Break out center of drain using pliers.
  - Use a sharp 3/8" chisel to cut across the drain where you want to start and stop.
  - Using the chisel, cut a piece out of the sides at least 1" long.
- With tin snips, split the top of each side. (A saw can be used to split the top; be sure not to cut below the line shown in drawing.)
- Using a 3/8" chisel, cut the thin inside brace flush with the heavy plastic ledge.
  - Using a 1 1/2" or 2" wood chisel, cut through outside as shown and remove outside piece. It is important not to cut below the heavy plastic lip. Remove indicated area only!
- Place a bead of caulk if desired.
  - Insert (cut to length) drain top.

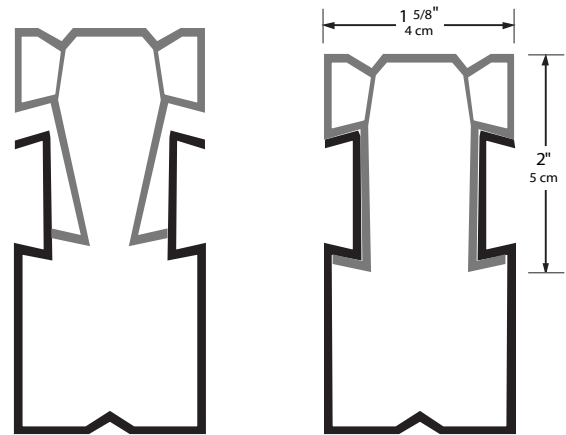

## Desired goal:

Remove the old top without cutting below the heavy plastic lip.

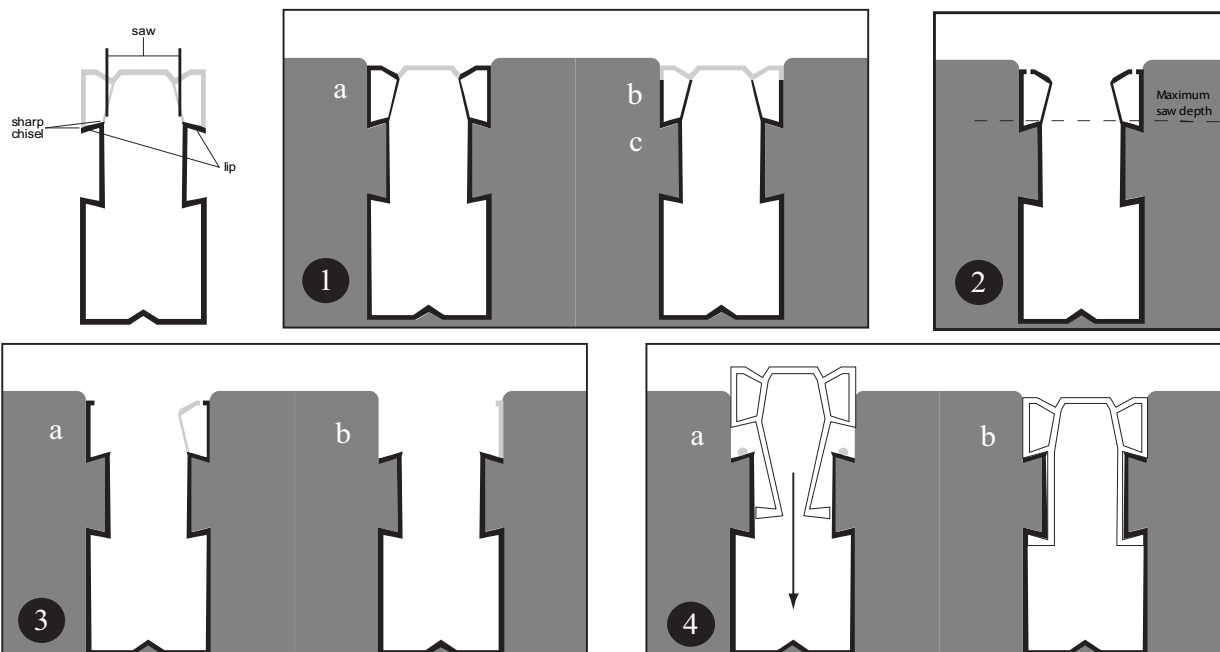

# Drain Rite® Accessories

Drain Rite connection accessories are made from the same lineal, heavy-wall one piece materials as our Drain Rite. Drain Rite spouts, caps and covers are made to complete your drainage system. All connections feature obstruction free water flow, because they use outside couplers.

- All available individually.
- All spouts connect to standard 1½ inch PVC pipe for carrying away water.

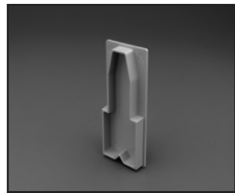
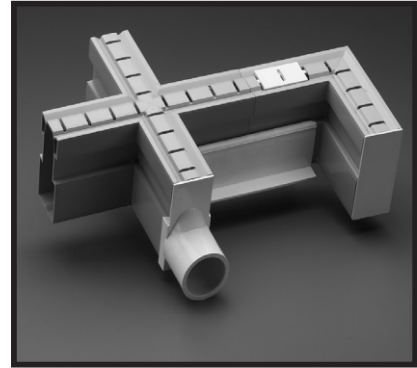

End Cap

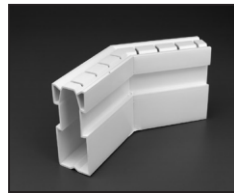

45 Degree Angle

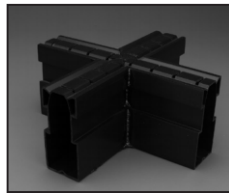

Cross

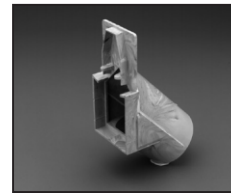

End Spout



Down Spout

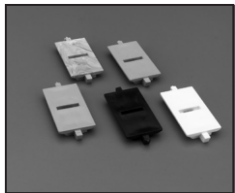

Clean Out Covers

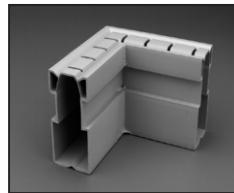

90 Degree Angle

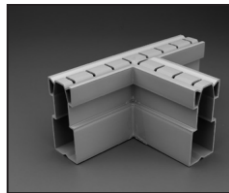

Tee

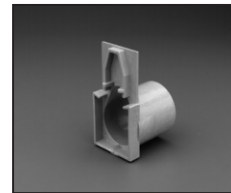

Straight Spout

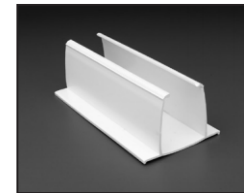

Coupler

Catalog Item #	Description	Catalog Item #	Description
DX45C	45 Degree Angle - Charcoal	DXC	Coupler - White
DX45G	45 Degree Angle - Gray	DXCOCC	Clean Out Cover - Charcoal
DX45M	45 Degree Angle - Marble	DXCOCG	Clean Out Cover - Gray
DX45T	45 Degree Angle - Tan	DXCOCM	Clean Out Cover - Marble
DX45W	45 Degree Angle - White	DXCOCT	Clean Out Cover - Tan
DX90C	90 Degree Angle - Charcoal	DXCOCW	Clean Out Cover - White
DX90G	90 Degree Angle - Gray	DXDS	Down Spout - White
DX90M	90 Degree Angle - Marble	DXSSC	Straight Spout - Charcoal
DX90T	90 Degree Angle - Tan	DXSSG	Straight Spout - Gray
DX90W	90 Degree Angle - White	DXSSM	Straight Spout - Marble
DXXC	Cross - Charcoal	DXSST	Straight Spout - Tan
DXXG	Cross - Gray	DXSSW	Straight Spout - White
DXXM	Cross - Marble	DXESC	End Spout - Charcoal
DXXT	Cross - Tan	DXESG	End Spout - Gray
DXXW	Cross - White	DXESM	End Spout - Marble
DXTC	Tee - Charcoal	DXEST	End Spout - Tan
DXTG	Tee - Gray	DXESW	End Spout - White
DXTM	Tee - Marble	DXECC	End Cap - Charcoal
DXTT	Tee - Tan	DXECG	End Cap - Gray
DXTW	Tee - White	DXECM	End Cap - Marble
		DXECT	End Cap - Tan
		DXECW	End Cap - White

# Pave Rite™ & Accessories

Pave Rite™ is specially designed for superior drainage within paver decking. It is a two piece, linear, water channel draining system. Due to its design and heavy walled construction, warping and bowing found in other drain systems are greatly reduced. Pave Rite's full two inch top provides greater water flow from the deck surface, and it has the stylish look that is perfect for upscale paver installations.

- All extrusions and compounding are done in-house to assure the highest quality.

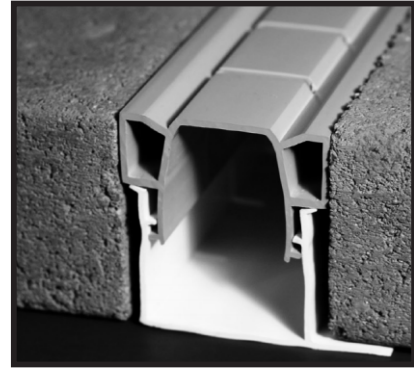

Product Detail	Description
Coverage	80 ft. per carton (24.38 m)
Contents	8 - 10 ft. lengths (3.05 m)
Ctn Measurements	136" x 8 1/2" x 7 1/2" (345 cm x 21.6 cm x 19 cm)
Weight	48 lbs (21.77 kg)
Shipping Information	Freight Truck, Ocean or Air

Catalog Item #	Description
PRW	Pave Rite - White
PRT	Pave Rite - Tan
PRG	Pave Rite - Grey
PRM	Pave Rite - Marble
PRC	Pave Rite - Charcoal
PRB	Pave Rite - Base Only
PRTW	Pave Rite - White Top Only
PRTT	Pave Rite - Tan Top Only
PRTG	Pave Rite - Grey Top Only
PRTM	Pave Rite - Marble Top Only
PRTC	Pave Rite - Charcoal Top Only
PRX45W	Pave Rite 45 Degree Angle - White
PRX45T	Pave Rite 45 Degree Angle - Tan
PRX45G	Pave Rite 45 Degree Angle - Grey
PRX45M	Pave Rite 45 Degree Angle - Marble
PRX45C	Pave Rite 45 Degree Angle - Charcoal
PRX90W	Pave Rite 90 Degree Angle - White
PRX90T	Pave Rite 90 Degree Angle - Tan
PRX90G	Pave Rite 90 Degree Angle - Grey
PRX90M	Pave Rite 90 Degree Angle - Marble
PRX90C	Pave Rite 90 Degree Angle - Charcoal
PRXSSW	Pave Rite Straight Spout - White
PRXSST	Pave Rite Straight Spout - Tan
PRXSSTG	Pave Rite Straight Spout - Grey
PRXSSTM	Pave Rite Straight Spout - Marble
PRXSSTC	Pave Rite Straight Spout - Charcoal
PRXESW	Pave Rite End Spout - White
PRXEST	Pave Rite End Spout - Tan
PRXESG	Pave Rite End Spout - Grey
PRXESM	Pave Rite End Spout - Marble
PRXESC	Pave Rite End Spout - Charcoal

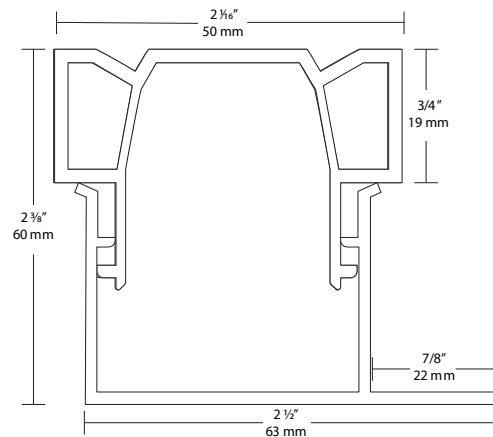

Spouts are connected to 1 1/4" PVC.

# Control Joint™

Control Joint™ is a PVC lineal contractual joint system for concrete crack control. Control Joint encourages the concrete to crack in a designated acceptable manner. Control Joint has excellent weatherability. It is virtually unaffected by chlorine and pool chemicals.

- Designed with side fins to prevent the free flow of water to the subsoil.
- Made with high impact PVC and UV inhibitors.
- Installs quickly just after screeding but before any stiffening starts.

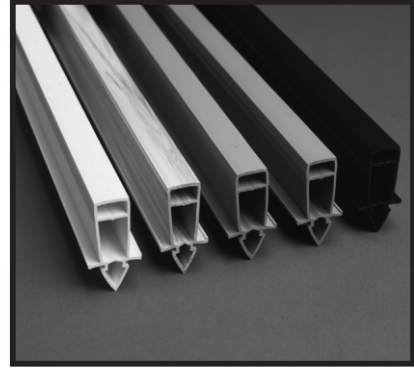

Product Detail	Description
Coverage	200 ft. per carton (70 m)
Contents	20 - 10 ft. lengths (3.04 m)
Ctn Measurements	124" x 5 1/4" x 7" (315 cm x 13.3 cm x 17.8 cm)
Weight	36 lbs (16.3 kg)
Shipping Information	Freight Truck, Ocean, or Air

Catalog Item #	Description
CJC	Control Joint - Charcoal
CJG	Control Joint - Gray
CJM	Control Joint - Marble
CJT	Control Joint - Tan
CJW	Control Joint - White

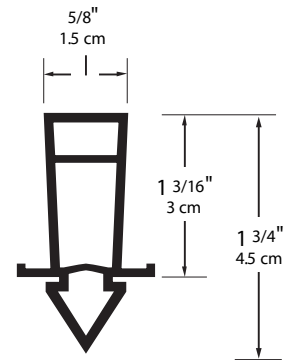

## Expansion Base

Good concrete practices necessitate the periodic use of full expansion as well as contractual joints. The need for full expansion joints is fulfilled by simply snapping a Mortex Expansion Base to a section of Control Joint.

- A Control Joint and Expansion Base combination can be used to stop and restart a concrete pour.
- When used with Control Joint, it acts as a screed guide for concrete finishing.

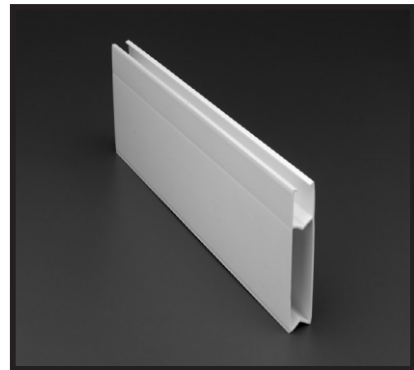

Product Detail	Description
Coverage	240 ft. per carton (73.1 m)
Contents	24 - 10 ft. lengths (3.04 m)
Ctn Measurements	124" x 5 1/4" x 7" (315 cm x 13.3 cm x 17.8 cm)
Weight	40 lbs (18.1 kg)
Shipping Information	Freight Truck, Ocean, or Air

Catalog Item #	Description
CXEB	Expansion Base

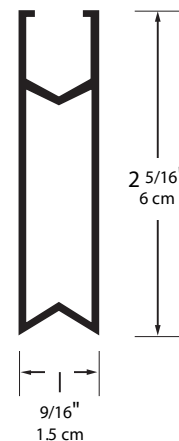

# Control Joint™ Technical Info.

## PRODUCT DESCRIPTION

CONTROL JOINT/EXPANSION BASE are a PVC lineal joint system that provides room for concrete to expand and contract with climatic changes.

## INTENDED USE

CONTROL JOINT/EXPANSION BASE are used for flat work concrete in foot traffic areas such as walkways, patios, courtyards and swimming pool decks. CONTROL JOINT encourages the concrete to crack in a designated acceptable manner. EXPANSION BASE, when snapped onto the “V” bottom of the CONTROL JOINT forms a full contraction/expansion joint in a 4” (10 cm) concrete pour. This combination can be staked down and used to stop and start a pour. EXPANSION BASE can also be used to couple lengths of CONTROL JOINT together.

## COMPOSITION & MATERIALS

Mortex compounds its own plastic formulations for CONTROL JOINT/EXPANSION BASE. We add acrylic impact modifiers to our polyvinyl chloride for superior exterior strength. Titanium dioxide is added for protection against the harmful effects of ultraviolet radiation.

## LIMITATIONS

CONTROL JOINT should not be subjected to xylene based acrylic sealers for extended periods as shape and strength will be affected. CONTROL JOINT should be stored indoors to keep protective tape flexible and easy to remove. The use of CONTROL JOINT and EXPANSION BASE should be limited to pedestrian traffic.

## TECHNICAL DATA

Use the Deck Width Multiplier formula (DWM), to determine distance between joints. The DWM formula is simply the width of deck times the DWM Constant, which yields the Feet Spaced ( $W \times DWM = Fs$ ). A DWM Constant can be any number from a minimum of 1 to a maximum of 3. A lower DWM Constant will yield more joint per unit area of decking. We suggest using a DWM constant of 1.5.

For Example: A deck or sidewalk is 3' wide (1 m) Using a DWM of 1.5, an equation would be  $3' \times 1.5$  (DWM) = 4.5' (1.37 m.) The conclusion from this equation is to place a CONTROL JOINT every 4.5' (1.37 m.) **Note:** Never have bays larger than 12' x 12' (3.66 m x 3.66 m) without placing a joint. We suggest that all inside angles be protected with a joint to control concrete cracking. Side Fins hold the joint in the hardened concrete and prevent the free flow of water to the subsoil. The “V” profile gives added assurance that the deck will crack in the desired place. For protection during the pour, protective tape has been applied to the exposed surface.

## COLORS

CONTROL JOINT: Charcoal, Gray, Marble, Tan and White

EXPANSION BASE: White only (Not visible when installed with CONTROL JOINT, except from edge of deck).

## WEATHER RESISTANCE

Garner Impact Testing: After 1000 hours of weathering, CONTROL JOINT did not show any significant change in impact resistance values. Under UVA 340 bulbs, Whiteness (L value) remained constant. CONTROL JOINT has excellent weatherability. It is virtually unaffected by chlorine, pool chemicals and muriatic acid.

## MAINTENANCE

CONTROL JOINT is maintenance free. When using concrete stains or sealers, contact the manufacturer for compatibility information.

# Control Joint™ Instructions

## NECESSARY TOOLS

- Miter Saw or Hack Saw

## OPTIONAL TOOLS

- Hammer
- Wooden or Steel Stakes

## CONTROL JOINT

1. Where only contractual crack control is desired, precut the Control Joint to the desired length. Position the Control Joint by rocking it into the fresh concrete either just before or after tamping. Score along both edges with an edging tool.

## CONTROL JOINT WITH EXPANSION BASE

2. Good concrete practices necessitate the periodic use of full expansion as well as contractual joints. This need is fulfilled by simply snapping the Mortex Expansion Base to the bottom of the Control Joint. This method also affords an excellent joint when the concrete pour is to be stopped and continued later.
3. When the complete unit is used, prestaking is advisable.

## CONTROL JOINT WITH EDGE CAPS

4. The perfect edge finish for cantilever decks is made possible with the Mortex Nose, Flair, or French Cap which is locked into the form before the pour.
5. Align Cap spear at form and push spear into form. Turn cap sideways to clear the form's cove strip and then reposition the cap against the form band.
6. Slide the locking button onto the cap's spear and push securely into place. When the concrete has finished its initial set, twist the button to break the cap free from the form.

**Note:** If installing a concrete overlay, apply the overlay to the deck before removing protective tape.

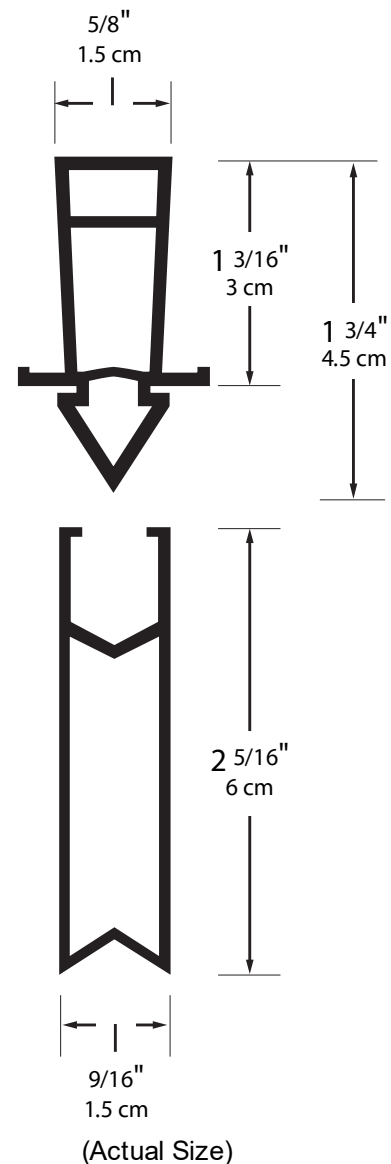

# Control Joint™ Replacement Top

Control Joint Replacement Top™ is an innovative, convenient and easy way to repair or change the color of existing joints. Control Joint Replacement Top fits over the top of existing joints.



Product Detail	Description
Coverage	200 ft. per carton (60.96 m)
Contents	25 - 8 ft. lengths (3 m)
Ctn Measurements	3.25" diameter x 102" (8.26 cm x 259 cm)
Weight	16 lbs (13.6 kg)
Shipping Information	Freight Truck, Ocean, Air, UPS

Catalog Item #	Description
CXRTC	Control Joint Replacement Top - Charcoal
CXRTG	Control Joint Replacement Top - Gray
CXRTM	Control Joint Replacement Top - Marble
CXRTT	Control Joint Replacement Top - Tan
CXRTW	Control Joint Replacement Top - White

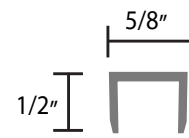

## INSTRUCTIONS:

### NECESSARY TOOLS

- Circular Saw (1/8" blade)

### OPTIONAL TOOLS

- Miter Saw
- High-Pressure Washer

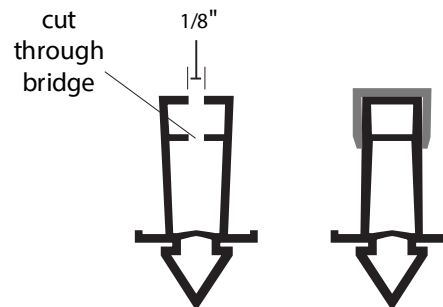

## INSTALLATION

1. Saw cut the existing control joint down to the middle with a 1/8" wide blade (must saw top and bridge.)
2. Set the saw to cut 1/2" deep, so that the inside bridge is also cut.
3. Clean debris from along both sides of control joint. A high pressure washer works well.
4. The Control Joint Replacement Top can then be placed over the top and secured with PVC glue.

# Foam Fiber Joint

Foam Fiber Joint is an adaptable solution for crack control where Control Joint is impractical. Foam Fiber Joint's flexible polyethylene cushioned joint is perfect between existing structures, such as walls and foundations, and/or a new concrete pour.

- Each roll is perforated in two or three areas allowing use of half or full widths to accommodate the thickness of the pour
- Top segment is removable allowing space for caulking with a self-leveling sealant.
- Resilient and cost-effective
- Environmentally friendly.....manufactured without ozone damaging CFC's.
- Resistant to moisture damage and temperature extremes

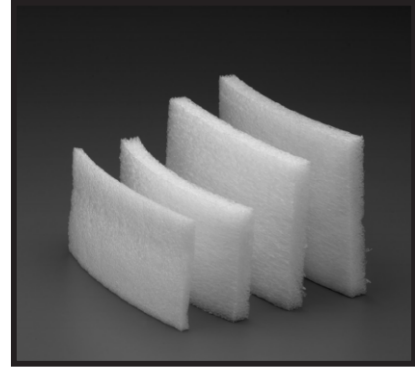

Product Detail	Description
Coverage & Contents	CXFJ12: 1 roll of : 1/2" x 3" x 50 linear feet per carton (15.25 m) CXFJ14: 1 roll of: 1/4" x 3" x 125 linear feet per carton (38 m) CXFJ124: 4 rolls of: 1/2" x 4" x 60 linear feet per carton (18.3 m)
Ctn. Measurements	CXFJ12: 19 1/2" x 19 1/2" x 3 1/2" (49.5 cm x 49.5 cm x 8.9 cm) CXFJ14: 25" x 24" x 3 1/2" (63.5 cm x 61 cm x 8.9 cm) CXFJ124: 19" height x 22" diameter bag (48.3 cm x 55.9 cm)
Weight	CXFJ12: 2 lbs. (0.9 kg) CXFJ14: 3 lbs. (1.4 kg) CXFJ124: 7 lbs. (3.2 kg)
Shipping Information	UPS, FedEx, Freight Truck, Ocean or Air

Catalog Item #	Description
CXFJ12	Foam Fiber Joint 1/2" x 3" x 50' - 3 Cuts - 1 ROLL
CXFJ14	Foam Fiber Joint 1/4" x 3" x 125' - 3 Cuts - 1 ROLL
CXFJ124	Foam Fiber Joint 1/2" x 4" x 60' - 2 cuts - 4 ROLLS

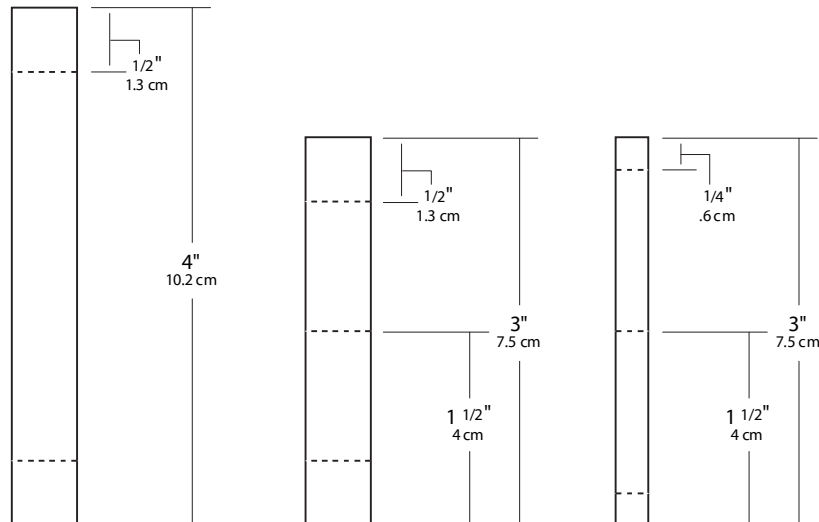



# Cantilever Pool Forms

Mortex Cantilever Forms offer the quality, value and ease of use you have come to expect from Mortex.

- Quick to set and even quicker to remove.
- Cove strip acts as a water stop and eliminates the need to grout or caulk the joint between the tile and deck.
- Form flexibility gives designers and contractors endless options in pool shapes (1 ft. radius capability with use of filament tape).
- Technically superior because spear and button locking system holds tight and releases with a twist of the wrist.

## Keystone, Poly, French Curve, Stone Edge

Product Detail	Description
Coverage	112 ft. of Form Band and 112 ft. of Cove Strip (34.13 m) in
Contents	14 - 8 foot lengths (2.43 m); Spear Pack containing 110 spear & buttons, 120 nails and one roll of filament tape
Ctn Measurements	13" x 13" x 102" (33 cm x 33 cm x 259 cm)
Weight	24 lbs (10.9 kg)
Shipping Information	UPS, FedEx, Freight Truck, Ocean or Air

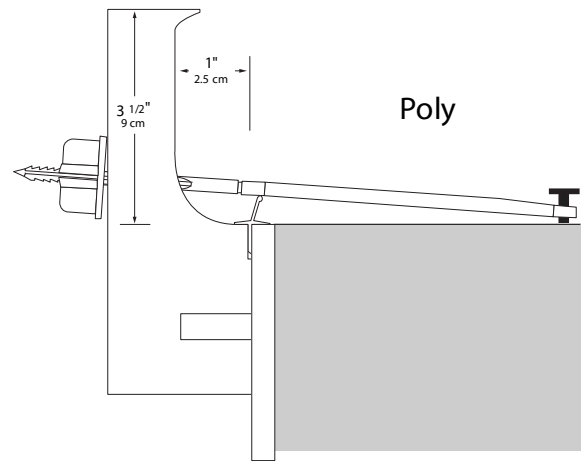
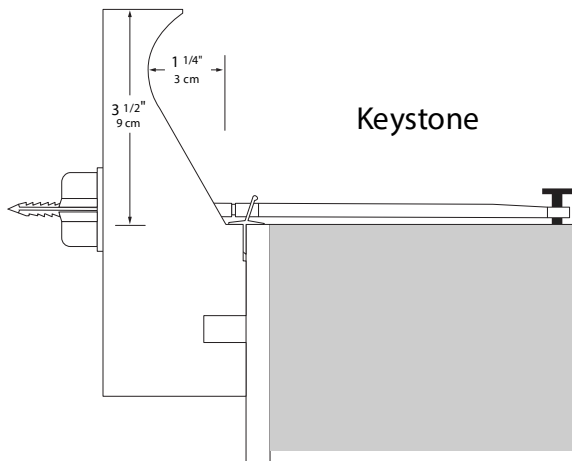
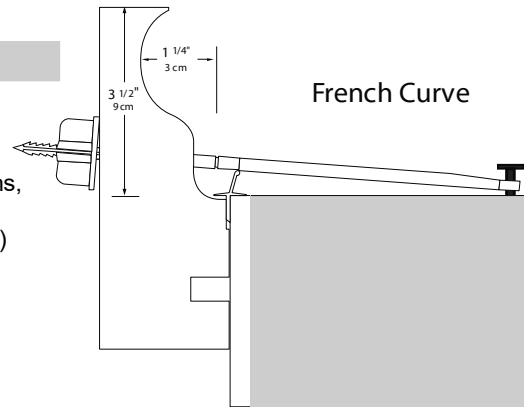

## Commercial and Hemi

Product Detail	Description
Coverage	80 ft. of Form Band and 80 ft. of Cove Strip (24.39 m) in
Contents	10 - 8 foot lengths (2.43 m); Spear pack containing 80 commercial spears, buttons & nails and one roll of Filament Tape
Ctn Measurements	13" x 13" x 102" (33 cm x 33 cm x 259 cm)
Weight	24 lbs (10.9 kg)
Shipping Information	UPS, FedEx, Freight Truck, Ocean, or Air

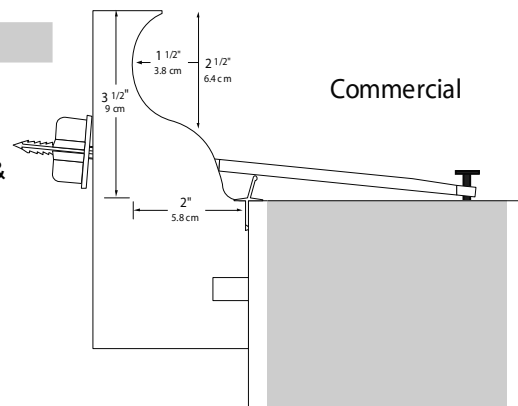

**Note:** Commercial form shape is not compatible with French Caps.

\* All forms available with Tie Wires.

# Cantilever Pool Forms

Keystone

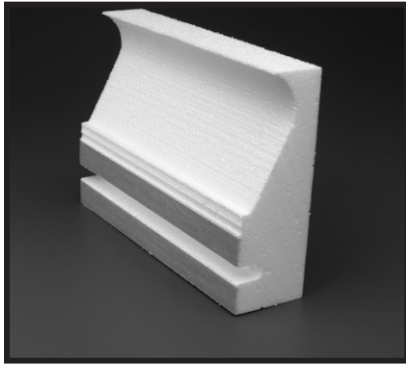

Poly

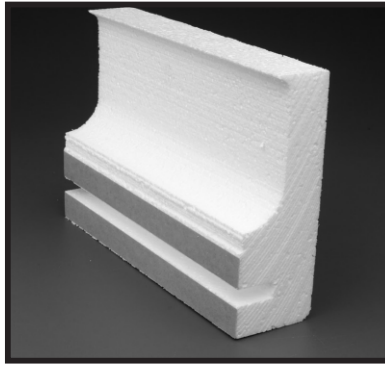

French Curve

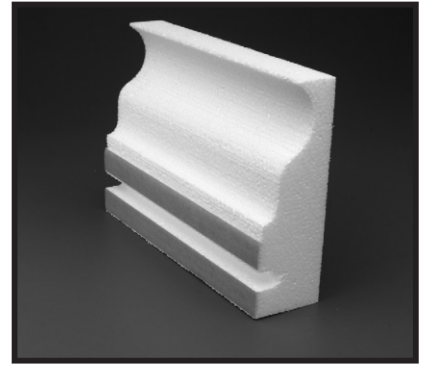

Stone Edge



Stone Edge

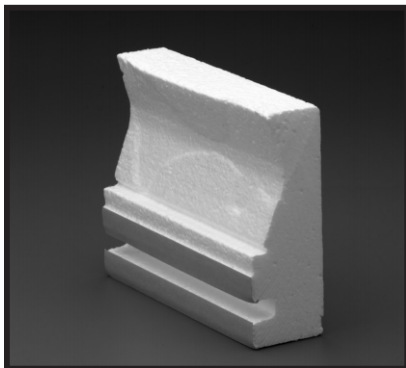



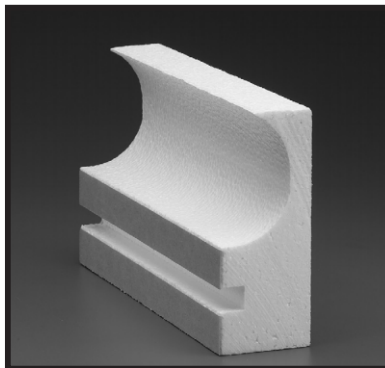

Hemi

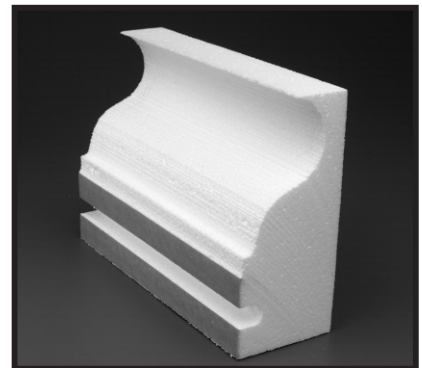

Commercial

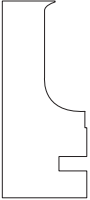

# Cantilever Form Codes

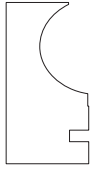
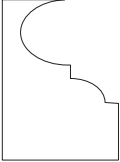
Catalog Item #	Description	
<b>STANDARD CANTILEVER FORMS (INCLUDES SPEARS &amp; BUTTONS WHERE INDICATED)</b>		
FXK6R	Keystone Form 6" Radius - 6 pieces	
FKFFO	Keystone Form Bands Only - 112 ft.	
FKF	Keystone Form - White Cove Strip - Spears & Buttons - 112 ft.	
FKFCT	Keystone Form - Tan Cove Strip - Spears & Buttons - 112 ft.	
FKFCG	Keystone Form - Grey Cove Strip - Spears & Button - 112 ft.	
FKFCC	Keystone Form - Charcoal Cove Strip - Spears & Buttons - 112 ft.	
FXP6R	Poly Form 6" Radius - 6 pieces	
FPFFO	Poly Form Bands Only - 112 ft.	
FPF	Poly Form - White Cove Strip - Spears & Buttons - 112 ft.	
FPFCT	Poly Form - Tan Cove Strip - Spears & Buttons - 112 ft.	
FPFCG	Poly Form - Grey Cove Strip - Spears & Buttons - 112 ft.	
FPFCC	Poly Form - Charcoal Cove Strip - Spears & Buttons - 112 ft.	
FFCFFO	French Curve - Form Bands Only - 112 ft.	
FFCF	French Curve - White Cove Strip - Spears & Buttons - 112 ft.	
FFCFCT	French Curve - Tan Cove Strip - Spears & Buttons - 112 ft.	
FFCFCG	French Curve - Gray Cove Strip - Spears & Buttons - 112 ft.	
FFCFCC	French Curve - Charcoal Cove Strip - Spears & Buttons - 112 ft.	
FCOMFFO	Commercial Form Bands Only - 80 ft.	
FCOMF	Commercial Form - White Cove Strip - Spears & Buttons - 80 ft.	
FCOMFCT	Commercial Form - Tan Cove Strip - Spears & Buttons - 80 ft.	
FCOMFCG	Commercial Form - Gray Cove Strip - Spears & Buttons - 80 ft.	
FCOMFCC	Commercial Form - Charcoal Cove Strip - Spears & Buttons - 80 ft.	
FSEFFO	Stone Edge Form Bands Only - 112 ft.	
FSEF	Stone Edge Form - White Cove Strip - Spears & Buttons - 112 ft.	
FSEFCT	Stone Edge Form - Tan Cove Strip - Spears & Buttons - 112 ft.	
FSEFCG	Stone Edge Form - Grey Cove Strip - Spears & Buttons - 112 ft.	
FSEFCC	Stone Edge Form - Charcoal Cove Strip - Spears & Buttons - 112 ft.	
FHFFO	Hemi Form Bands Only - 80 ft.	
FHF	Hemi Form - White Cove Strip - Spears & Buttons - 80 ft.	
FHFCT	Hemi Form - Tan Cove Strip - Spears & Buttons - 80 ft.	
FHF CG	Hemi Form - Grey Cove Strip - Spears & Buttons - 80 ft.	
FHFCC	Hemi Form - Charcoal Cove Strip - Spears & Buttons - 80 ft.	
FOGFFO	OG Form Bands Only - 80 ft.	
FOG	OG Form - White Cove Strip - Spears & Buttons - 80 ft.	
FOGCT	OG Form - Tan Cove Strip - Spears & Buttons - 80 ft.	
FOGCG	OG Form - Grey Cove Strip - Spears & Buttons - 80 ft.	
FOGFCC	OG Form - Charcoal Cove Strip - Spears & Buttons - 80 ft.	
<b>FORMS WITH TIE WIRES</b>		
FKFT	Keystone Form - White Cove Strip - Tie Wires - 112 ft.	
FPFT	Poly Form - White Cove Strip - Tie Wires - 112 ft.	
FFCFT	French Curve - White Cove Strip - Tie Wires - 112 ft.	
FCOMFT	Commercial Form - White Cove Strip - Tie Wires - 112 ft.	
FSEFT	Stone Edge Form - White Cove Strip - Tie Wires - 112 ft.	
FHFT	Hemi Form - White Cove Strip - Tie Wires - 80 ft.	
FXSPS	Spear Pack with Screws Attachment Pack - 110 each	
FXTBS	Tie Bag with Screws Attachment Pack - 110 each	

**Note: All Forms with Tie Wires are also available with Colored Cove Strip.**

# Cantilever Form Instructions

## NECESSARY TOOLS

- Knife

## PREPARATION

- The tile must be pre-set, straight, and level. Set the tile even or above bond beam not below.
- Where the tile is above the bond beam, the tile man should build up cement level with the top of the tile and feather down to the bond beam.
- Be sure the tile is dust and moisture free.

## INSTALLATION

1. Remove the tape backing just ahead of attaching the form band.
2. Attach the Form against the tile with the bottom edge of the cove even with the top edge of the tile. As the form is positioned, press the band firmly against the tile.
3. Cut or space bands to avoid having a break in a sharp radius. Use a sharp knife; do not use a saw.
4. On 90 degree corners, miter with a sharp knife.
5. On outside curves, exert end pressure while attaching the bands against the tile (for curve installation see other side Curve Instructions).
6. Insert Cove Strip onto form in the position indicated in the diagram below.
7. Place a spear and button lock approximately every 14 inches. For the Keystone Form, slide the plastic spear through the oblong hole in the cove strip. For the Poly, French and Commercial Forms, slide the plastic spear over the top edge of the cove strip at a slight upward angle. Then push the spear through the form band. The depth of penetration is quickly ascertained by allowing the square lip of the spear to come to rest within the oblong hole of the cove strip or directly above the cove strip.
8. When the spear lip has been positioned at the cove strip hole, merely drive the cut nail through the hole in the end of the spear, anchoring the spear to the bond beam. With the spear nailed in place, slide the self-locking button onto the sharp end of the spear and push the button firmly against the form band.  
Option: Install Nose, Flair or French Caps to line up with Control Joints.
9. It is always advisable to remove 1/2 shovel of dirt from behind the back edge of the bond beam approximately every 4 feet, as insurance against any inward movement of the deck. It is also advisable to lightly sand the bond beam to prevent the concrete deck from adhering to the bond beam. Mastic or asphaltic cement can be applied behind the cove strip on the top flange if a water seal is desired.

**Note:** Do not pre-grout the face of the form. When the concrete has solidified to the point where the form can be removed, the button is rotated, severing the spear behind the surface of the concrete. Then, the form band is removed revealing the cantilever edge.

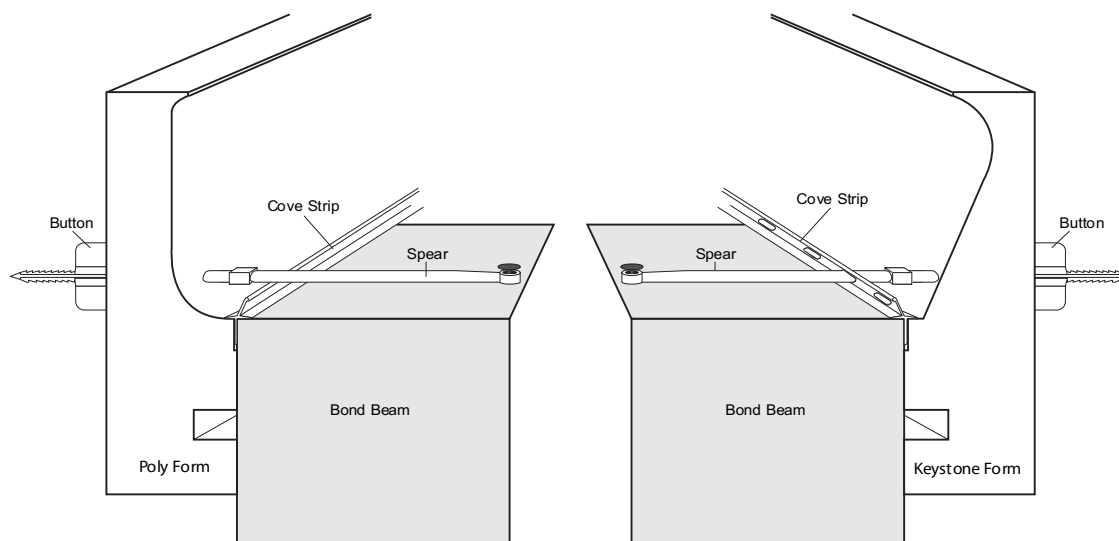

# Cantilever Form Instructions

## CURVE INSTRUCTIONS

In order to form tight radii without breaking the form bands, follow these procedures:

1. On outside radii, place the filament tape on the face of the form (in sufficient lengths to encompass the curve) in the two places shown in diagram 1.
2. For inside curves, place two strips of filament tape as shown in diagram 2. Duct tape may also be used.
3. After the filament tape is in place, pre-bend the form band before attaching the form against the tile.
4. The cove strip is implanted over the top edge of the tile between the tile and the form band. On a radius of under 4 feet, pre-bend the cove strip before pressing into position.

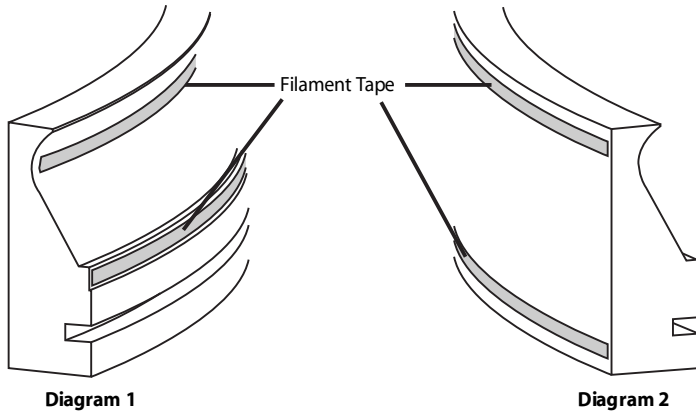

## SPEARS & BUTTONS / TIE WIRE

Mortex invented and pioneered the Spear and Button anchoring system, which is far superior to conventional tie wires. This patented button-locking mechanism enable these forms to be set with speed, and then cleanly removed with just a twist of the button.

Product Detail	Description
Contents	110 spear & buttons, 120 nails and one roll of filament tape
Shipping Information	UPS, FedEx, Freight Truck, Ocean or Air
Catalog Item #	Description
FXSP	Spear Pack with Nails
FXSPS	Spear Pack with Screws (for fiberglass pools)
FXTB	Tie Bag with Nails
FXTBS	Tie Bag with Screws (for fiberglass pools)

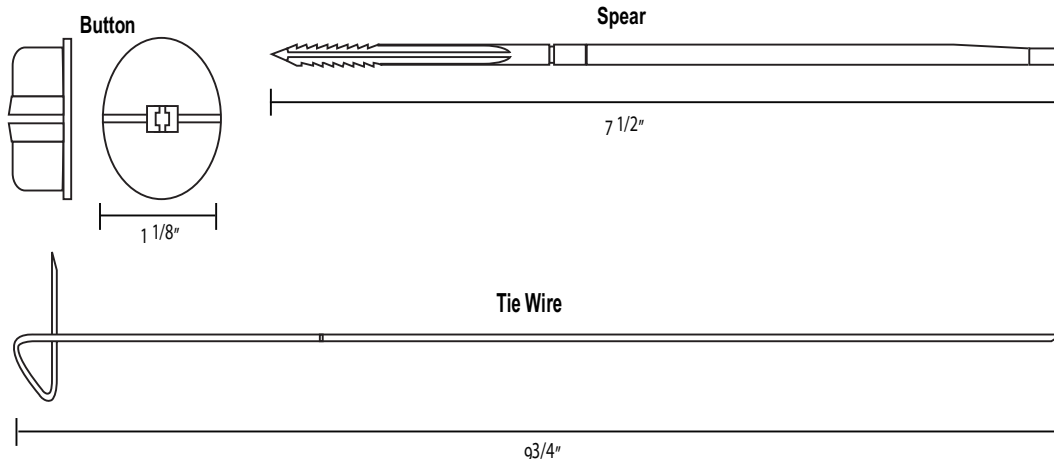

# Cantilever Form Dimensions

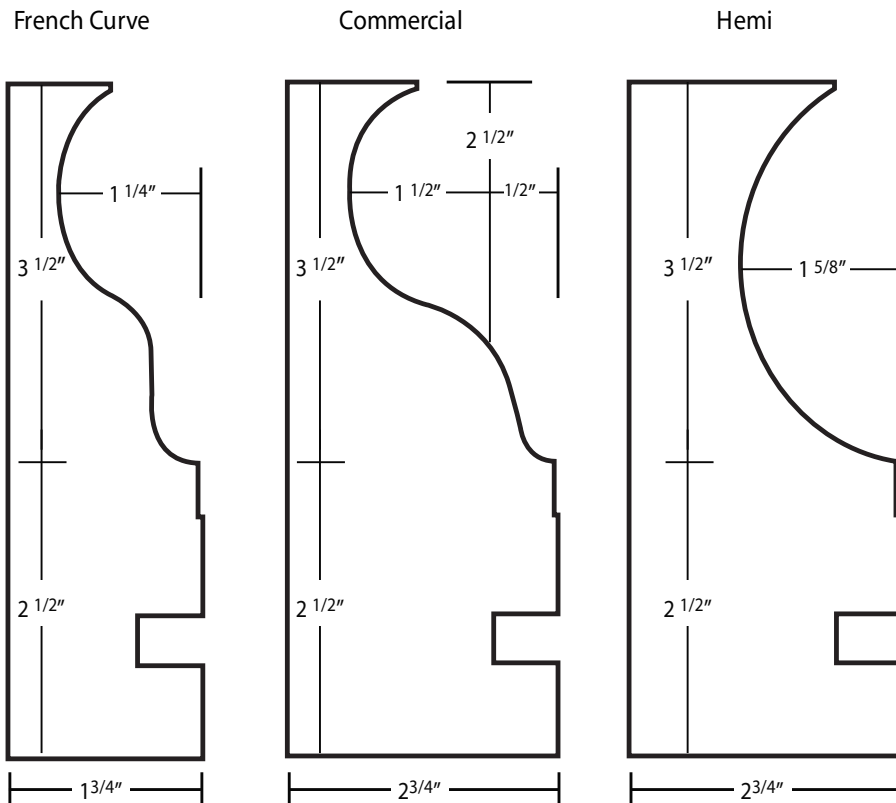
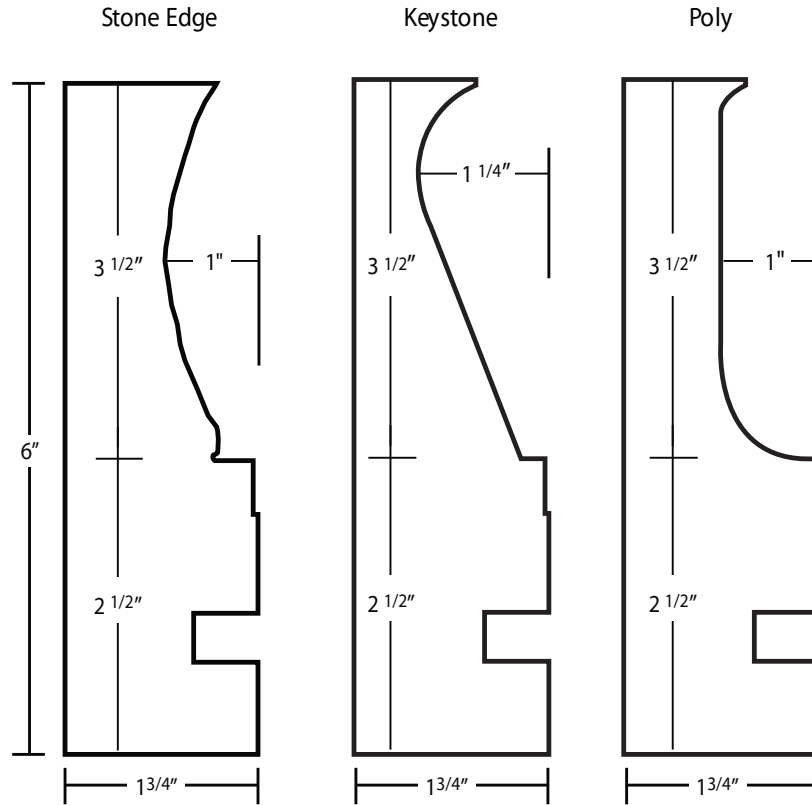

# Form Accessories

## NOSE, FLAIR & FRENCH CAPS

Bringing our advanced spear & button technology by elegantly completing a Control Joint with our Nose, Flair and French Caps. All caps are firmly held to the form and easily released from the form with a twist of the button.

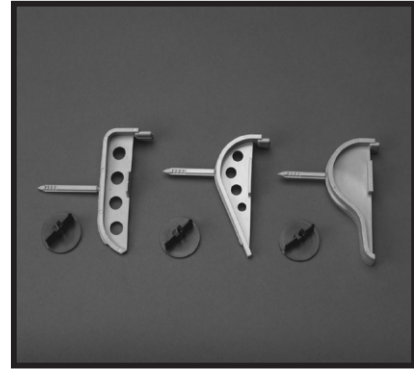

Product Detail	Description
Contents	50 caps and buttons per carton
Ctn Measurements	16" x 16" x 11" (41 cm x 41 cm x 28 cm)
Weight	2 lbs (0.91 kg)
Shipping Information	UPS, FedEx, Freight Truck, Ocean or Air

Catalog Item #	Description
CXFCC	Flair Cap - Charcoal
CXFCE	Flair Cap - Gray
CXFCEM	Flair Cap - Marble
CXFCT	Flair Cap - Tan
CXFCEW	Flair Cap - White
CXFRC	French Cap - Charcoal
CXFRE	French Cap - Gray
CXFREM	French Cap - Marble
CXFRT	French Cap - Tan
CXFREW	French Cap - White
CXNCC	Nose Cap - Charcoal
CXNCE	Nose Cap - Gray
CXNCEM	Nose Cap - Marble
CXNCT	Nose Cap - Tan
CXNCEW	Nose Cap - White

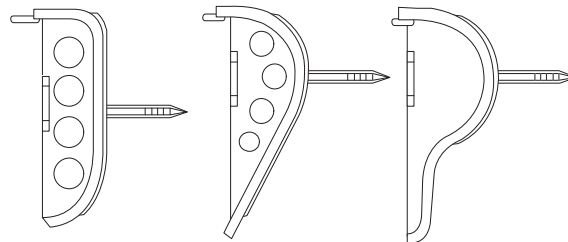

Nose Cap      Flair Cap      French Cap

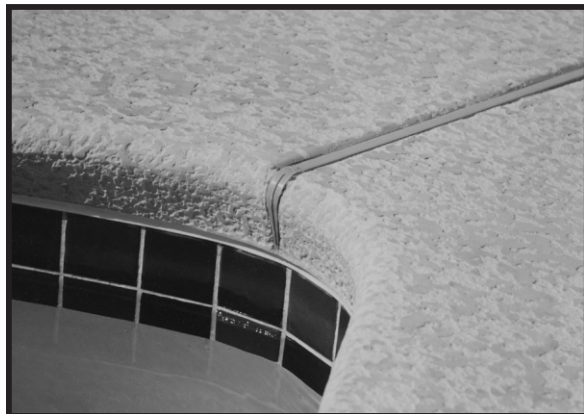

- Nose Caps are for use with our Poly Forms
- Flair Caps are for use with our Keystone Forms
- French Caps are for use with our French Curve Forms

## COVE STRIP

Cove strip forms a water stop between the top of the tile of the pool and the bottom of the edge of the concrete. It can be ordered in package sets with forms or separately by the item numbers below.

Catalog Item #	Description
FXCSKC	Cove Strip Charcoal - 112 ft.
FXCSKG	Cove Strip Gray - 112 ft.
FXCSKT	Cove Strip Tan - 112 ft.
FXCSKW	Cove Strip White - Keystone - 112 ft.
FXCSP	Cove Strip White - Poly - 112 ft.

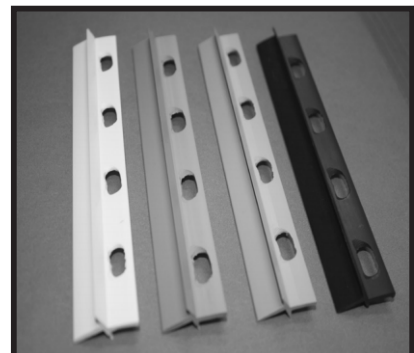

# Add-On's, Out Strips & One x One's

Where some applications call for extend height or other needs, Mortex Add-On, Out Strips and One By Ones are a perfect addition. Uses include: Epoxy-Rock applications, thicker deck edge, or increase deck extension. Also available: Add-On Poly Forms and No-Lip Poly Forms

**Note:** One By Ones, make a form incompatible with nose caps.

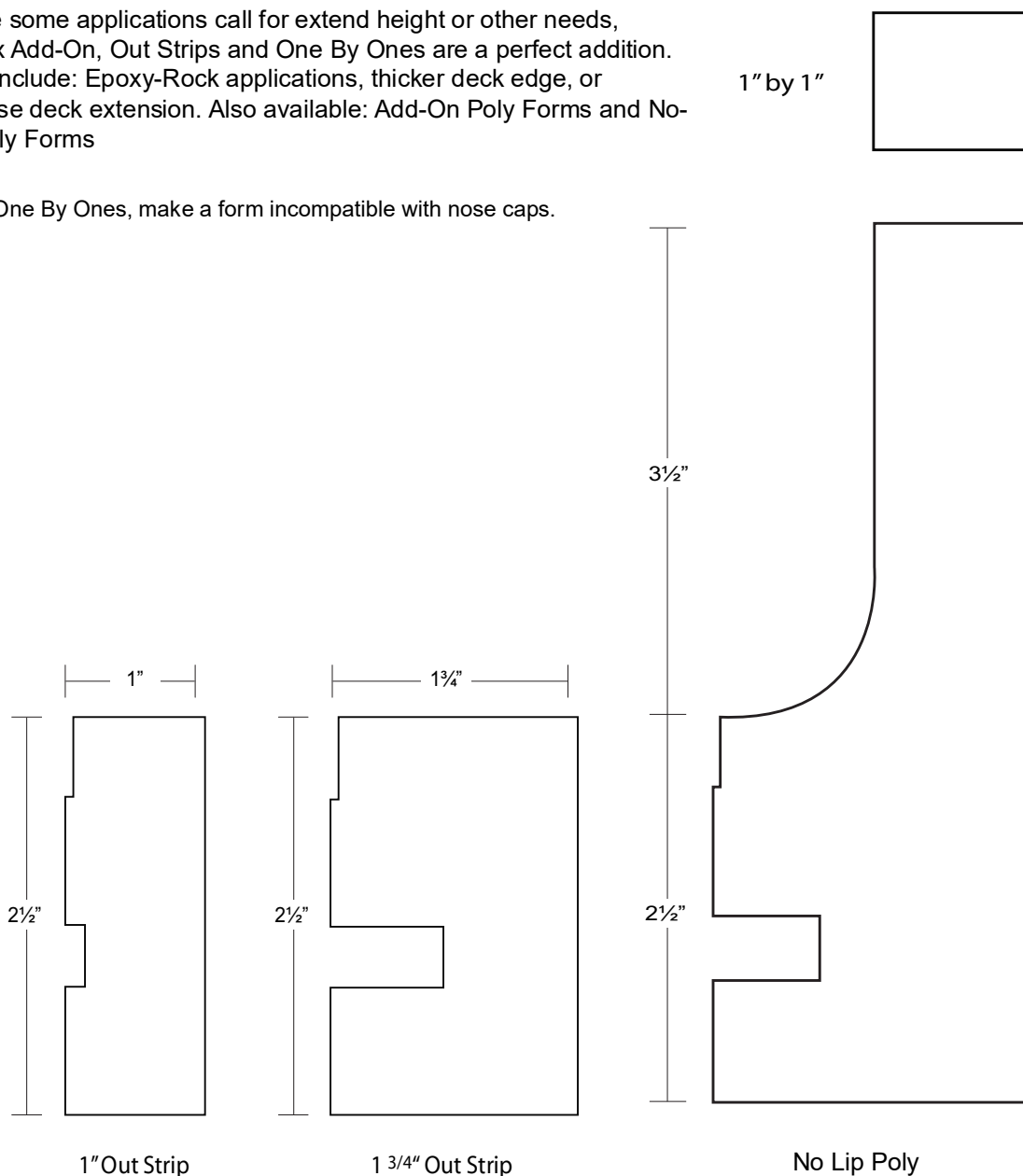

## Add-On Poly Form

### Product Detail

Contents

### Description

112 ft. Poly Form Bands (34.13 m) without top lip plus 112 ft. of White Cove Strip; 112 ft. of 1" x 1" Foam Strip (15/16" x 15/16") (2.38 cm x 2.38 cm) with double faced tape on one side.

Ctn. Measurements

Weight

Shipping Information

All 112 ft. quantities in 14 - 8 ft. (2.43 m) lengths

Includes 110 Tie Wires, Nails, Filament Tape

13" x 13" x 102" (33 cm x 33 cm x 259 cm)

24 lbs (10.9 kg)

UPS, FedEx, Freight truck, Ocean or Air

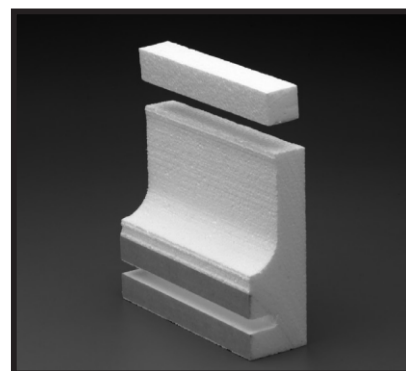

### Catalog Item #

FPAO

### Description

Add-On Poly Form



# Add-On's, Out Strips & One x One's

## No Lip Poly Form

Product Detail	Description
Contents	112 ft. Poly Form Bands (34.13 m) without top lip plus 112 ft. of White Cove Strip in 14 - 8 ft. (2.43 m) lengths. 110 Tie Wires, Nails, Roll of Filament Tape
Ctn. Measurements	13" x 13" x 102" (33 cm x 33 cm x 259 cm)
Weight	24 lbs (10.9 kg)
Shipping Information	UPS, FedEx, Freight truck, Ocean or Air
Catalog Item #	Description
FPNL	Poly Form No-Lip

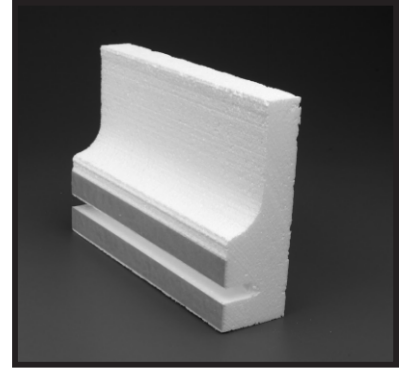

## One x Ones - To extend the height of the form 1"

Product Detail	Description
Content	1152 ft. of One x Ones (351.1 m) in 144 - 8 ft. lengths(2.43 m) Double Faced Tape on one side Total One by One Size - 15/16" x 15/16" (2.38 cm x 2.38 cm)
Ctn Measurements	13" x 13" x 102" (33 cm x 33 cm x 259 cm)
Weight	18 lbs (8.16 kg)
Shipping Information	UPS, FedEx, Freight truck, Ocean or Air
Catalog Item #	Description
FXP1X1	One By Ones



## 1" Out Strips - To extend the cantilever edge 1"

Product Detail	Description
Contents	416 ft. of Strips (126.8 m) in 52 - 8 ft. (2.43 m) lengths. 2 Rows of Double Faced Tape attached Strip Size - 15/16" W x 2.5" H (2.38cm x 6.67cm)
Ctn Measurements	13" x 13" x 102" (33 cm x 33 cm x 259 cm)
Weight	18 lbs (8.16 kg)
Shipping Information	UPS, FedEx, Freight truck, Ocean or Air
Catalog Item #	Description
FXP1	1 Inch Out-Strips

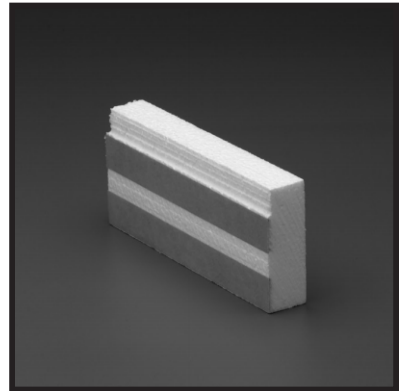

## 1 3/4" Out Strips - To extend the cantilever edge 1 3/4"

Product Detail	Description
Contents	224 ft. of Strips (68.3 m) in 28 - 8 ft. (2.43 m) lengths. 2 Rows of Double Faced Tape attached Strip Size - 1 7/8" W x 2 5/8 H (4.67cm x 6.67cm)
Ctn Measurements	13" x 13" x 102" (33 cm x 33 cm x 259 cm)
Weight	18 lbs (8.16 kg)
Shipping Information	UPS, FedEx, Freight truck, Ocean or Air
Catalog Item #	Description
FXP175	1 3/4 Inch Out-Strips

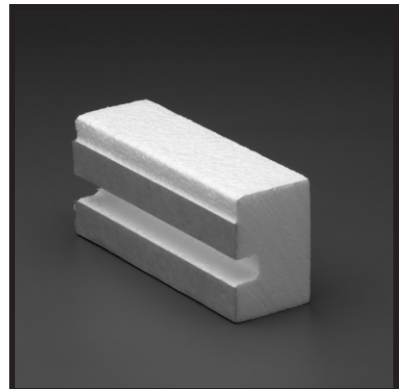

# Automatic Pool Cover Forms

With all the advantages of our standard Mortex cantilever deck forms, these forms are designed for those who require the built-in convenience of an automatic pool cover system.

**Note:** The Pool Cover Track, 1 1/2" Backwash Hose, Curved Bolts, and Nuts are not supplied by Mortex Manufacturing.

The Keystone shape extension is 1 3/4" and the Poly shape extension is either 1 3/4" or 1".

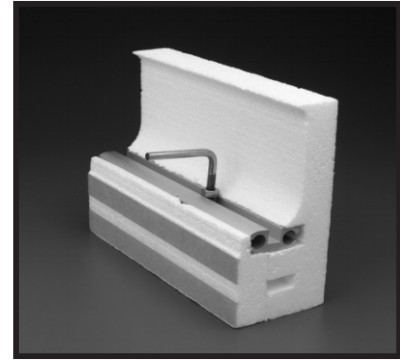

Product Detail	Description
Contents	<p><b>Keystone or Poly 1 3/4" Extension</b>            1 3/4" Extension: 112 ft. of both Form Bands &amp; White Cove Strip (34.13 m)            16' of 1 3/4" Extension (4.87 m)            96' of 1 3/4" Routed Extension (29.26 m)</p> <p><b>Poly 1" Extension</b>            16' of Forms Bands (4.87 m); 112' of White Cove Strip (34.13 m)            16' of 1 3/4" Extension (4.87 m); 96' of Routed Poly Form (29.26 m)            96' of 1" Routed Extension (29.26 m)</p>
Ctn Measurements	Packaged in two (2) cartons banded together. Box One: 13" x 13" x 102" (33 cm x 33 cm x 259 cm) Box Two: 8" x 9" x 100" (20 cm x 22.8 cm x 248 cm) Weight 32 lbs (14 kg)
Shipping Information	UPS, FedEx, Freight Truck, Ocean or Air
Catalog Item #	Description
FCK175	Keystone Pool Cover Form - 1 3/4" Ext.
FCP175	Poly Pool Cover Form - 1 3/4" Ext.
FCP1	Poly Pool Cover Form - 1" Ext.

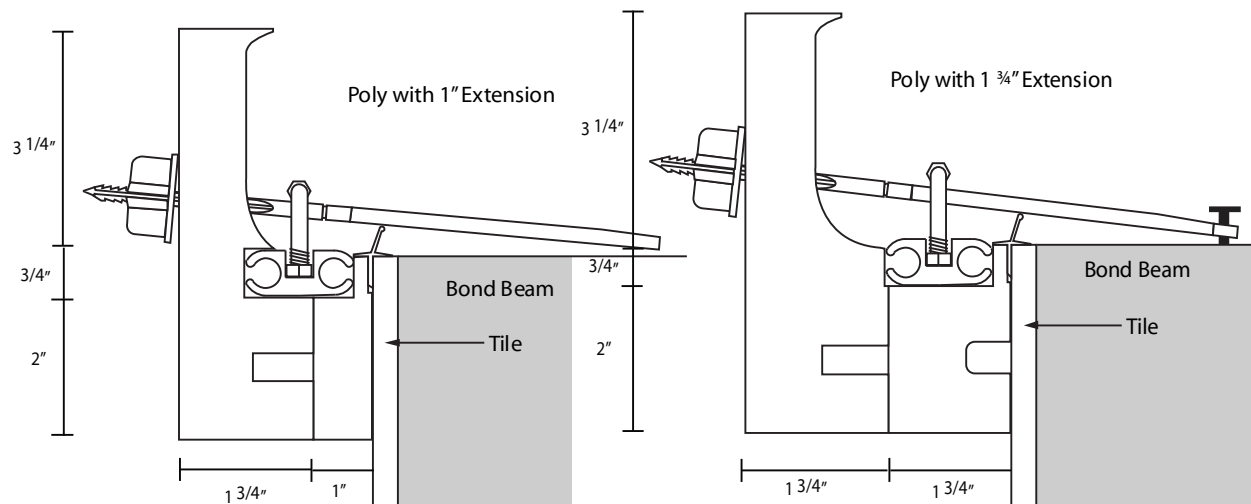

# Brackit™ Form System

Looking for a quality, cost efficient solution to forming concrete cantilevers integrating modern materials? Meet the Mortex Brackit™, our newest, patented form system from a long history of forming success. From Mortex's beginning, we pioneered both reusable and disposable forms starting in the 1960's. Even after 50 years, there is always something we think can be done better, less expensive or faster. Brackit form system does all three.

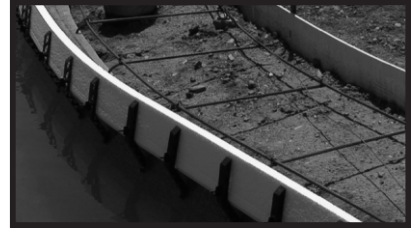

Pushing boundaries usually comes at a price. Fortunately with the Brackit form system, it is a much lower one with significant cost savings over either disposable or reusable competitor cantilever form options. Brackit will save you time, money and frustration by being specifically tailored to each individual application! Whether you are working with Gunite, Fiberglass, Vinyl Liner or Auto Pool Cover applications, Brackit Form System has you covered.

## Brackit Form System

Product Detail	Description
Coverage	Varies. See next page.
Contents	8 ft. lengths (2.43 m) lengths. Brackits sold separately.
Ctn Measurements	13" x 13" x 102" (33 cm x 33 cm x 259 cm)
Weight	17 lbs (7.7 kg)
Shipping Info	UPS, FedEx, Freight truck, Ocean or Air

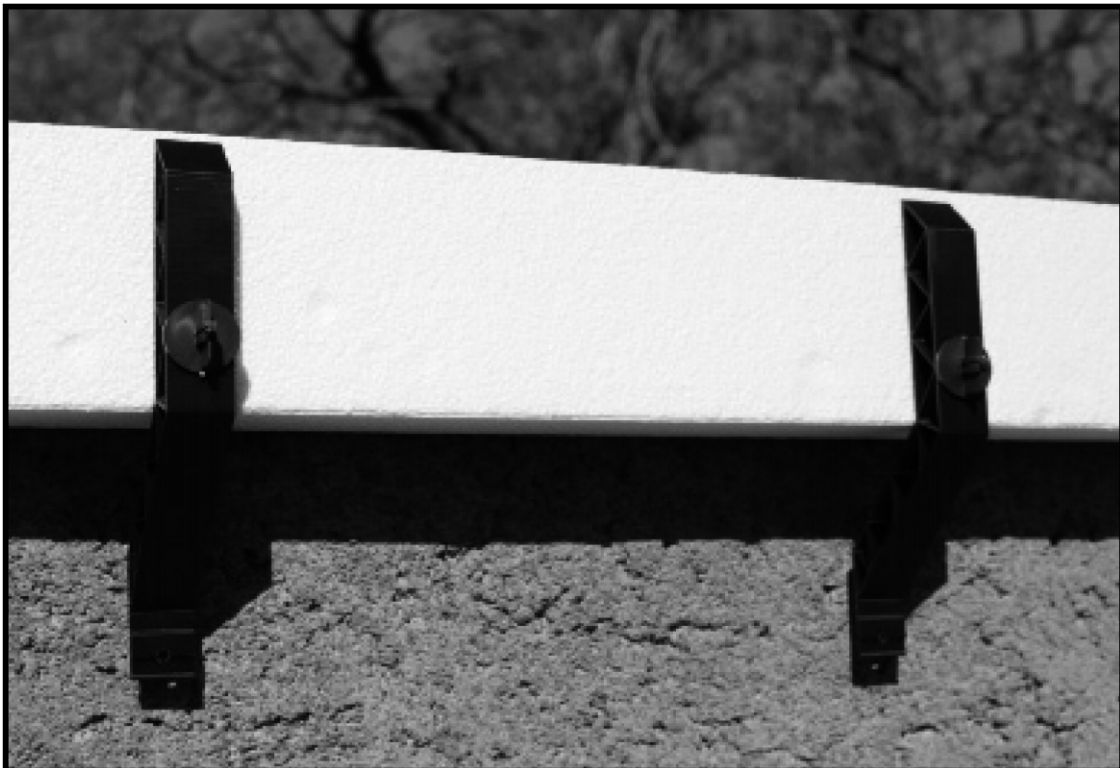
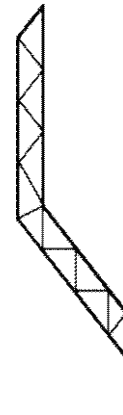

# Brackit™ Form System

## Getting Started:

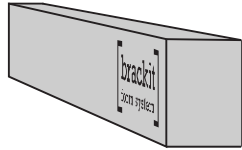

Choose profile shape, pool type and number of cartons required

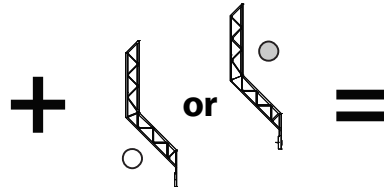

Choose correct bracket type and quantity required for spacing interval



## Pool Type

Profile Shape

	Pool Type			
	Gunite	Fiberglass	Vinyl Liner	Pool Cover
Profile Shape	SKU	SKU	SKU	SKU
	feet per carton	feet per carton	feet per carton	feet per carton
Keystone	FBK	FBFGK	FBLK	FBPCK*
	128	96	128	128
Poly	FBP	N/A	FBLP	FBPCP*
	128	N/A	128	128
Hemi	FBH	FBFGH	FBLH	FBPCH*
	96	96	96	96
Stone Edge	FBSEF	FBFGSEF	FBLSEF	FBPCSEF*
	128	96	128	128
Glow Rite	FBGR	FBFGGR	FBLGR	FBPCGR*
	128	96	128	128
French Curve	FBFC	FBFGFC	FBLFC	FBPCFC*
	128	96	128	128

### Disposable Form Set Includes:

Form Bands,  
Spears - Hook (FG, VL),  
Spears - Extended (Gunite, Cover),  
Buttons,  
Nails (Gunite, Cover),  
Screws (FG, VL),  
Filament Tape

### Reusable Brackets:

- FXBKT** - No Bumper for Gunite
- FXBKTR** - Rubber Bumper for Fiberglass, Vinyl Liner, or Pool Cover

Sold separately - by case (80 count) or individually.

Detailed training videos at:  
<http://brackitform.com>

## Bracket Type

Brackit SKU	<input type="radio"/> FXBKT	<input type="radio"/> FXBKTR	<input type="radio"/> FXBKTR	<input type="radio"/> FXBKTR
Spacing	1 per 12"	1 per 12"	1 per 12"	1 per 12"

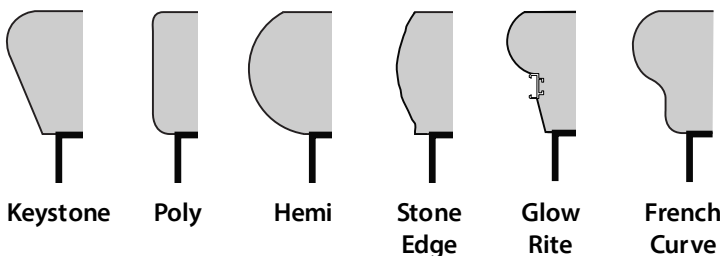

\* To correctly order Pool Cover SKU:

For CoverStar® track SKU's X0650 and X0953 only, use SKU above.

For Zodiac Cover Pools T4 track use SKU and append "Z", ie: FBPCZK for Keystone.

For APC Encapsulation track SKU and append "A", ie: FBPCAK for Keystone.

### Necessary Tools

- Knife, Drill (Corded or Cordless, 12V or greater), 1/4" Hex Nut Driver Bit. Optional: Caulk

### Contents

- 96 lineal ft. (29.26 m) or 128 lineal ft. (39 m) 8' lengths, Hook Spears, Tape, Screws.  
Requires a reusable Fiberglass/Vinyl Liner Bracket (FXBKTR) per 12 inches form applied.  
Brackets sold separately.

### PREPARATION

- Brackit form will easily create a beautiful concrete edge around a vinyl liner or fiberglass pool shell. The pool wall or shell must be leveled to the shell bond beam or vinyl track and backfilled to manufacturer's specifications.
- To achieve proper fit of Brackit form to the shell bond beam, remove dirt, mud or other loose particulate.

### INSTALLATION

1. Pre-arrange form bands to avoid having a break in a tight radius or ending above either skimmer or other shell protrusions. Use a sharp knife to cut forms and miter for 45 & 90 degree angle corners. Do not use a hand saw. **Helpful Hint:** Due to the extended width of the fiberglass form bands, pre-bend all inner and outer curved sections. See other side for Bending Instructions.
2. Place a spear approximately every 12 inches along the bond beam. On both sides of any break, use a spear as close to the break as spacing will allow.

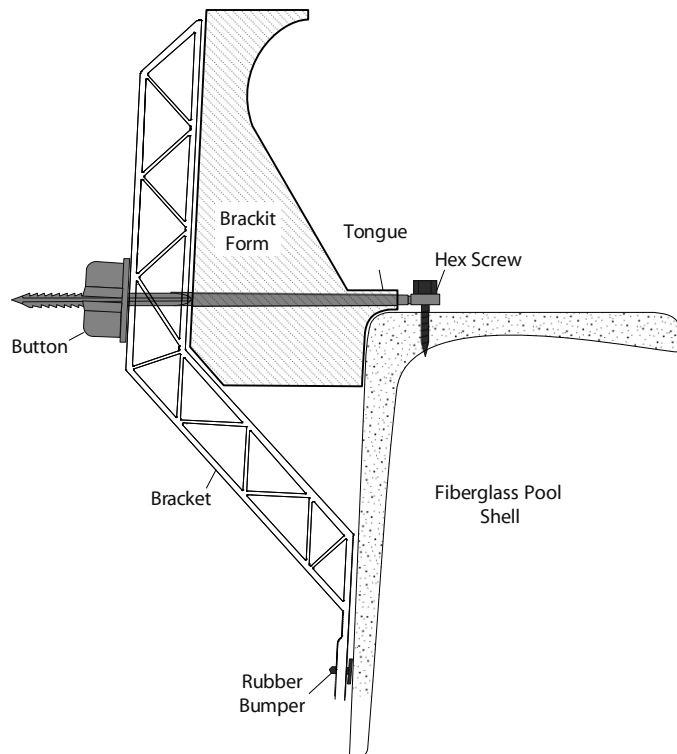

3. Place the form band against the top corner of the bond beam with the square tongue of the form level with the shell bond beam. Drill a pilot hole using the supplied 1/4" self tapping screws at 3/4" to 1" back from the tongue of the form.
4. While holding the form against the bond beam, align the shaft of the hook spear with the pre-drilled pilot hole. Push the hook spear through the tongue of the form band having the end protruding on the outside of the form at the line.
5. When the eyelet of the spear has been aligned properly to the pilot hole, secure by screwing a supplied 1/4" self-tapping screw through the spear into the existing pilot hole.
6. Place the upper hole of a plastic bracket over the protruding spear, followed by sliding the self-locking button onto the sharp end of the spear. Push the button firmly against outside of the bracket to snugly ratchet form band against shell bond beam.

### INSTALLATION - CONTINUED

7. While pouring the concrete, tap the outside of the form band, between brackets, with your hand to remove voids and holes bringing sufficient creme to the surface. **Note:** Do not pre-grout the face of the form.
8. When the concrete has solidified to the point where the form can be removed, rotate the button, severing the spear behind the surface of the concrete. Remove detached spear, button and bracket keeping them from falling in the pool. Then, the form band is removed revealing the cantilever edge. Float the surface of the edge with a small section of form band dipped in water. After finishing the deck on fiberglass pools, caulk notched area between pool shell and concrete slab as a water barrier.

### BENDING INSTRUCTIONS

In order to form tight radii without breaking the form bands, follow these procedures:

1. On inside radii, place two filament tape strips on the face of the form (in sufficient lengths to encompass the curve) below the tongue and place one in the upper curved form area as shown in Diagram 1.
2. For outside radii, place one strip of filament tape between the spear targeting line and the lower angle with an additional strip half way up the form as shown in Diagram 2. Duct tape may also be used.
3. After the filament tape is in place, pre-bend the form band before placing the form against the bond beam. Bend forms to a tighter radius than where intended. Forms are best bent slowly, making multiple passes.

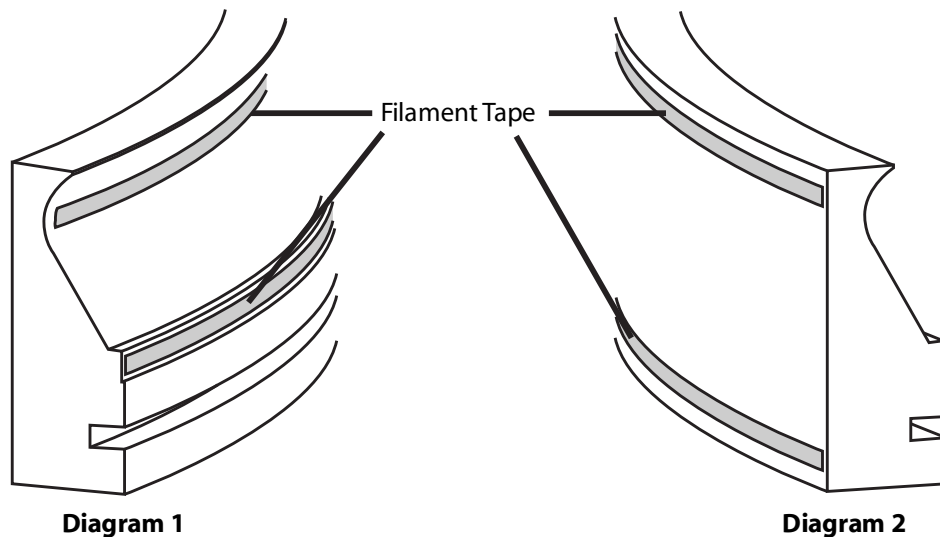

### Necessary Tools

- Knife, Hammer, Transit (recommended)

### Coverage

- 128 lineal ft. (48.8 m) in 8' lengths, Extended Spears, Tape, Nails. Requires a reusable Gunite Bracket (FXBKT) per 12 inches of form applied. Brackets sold separately.

### PREPARATION

- Brackit form will create a concrete edge on the bond beam without the presence of tile. The bond beam must be level with a square corner. Fill in any holes, gaps or irregularities in the bond beam corner.
- To achieve proper fit of Brackit form to the bond beam, remove protrusions, debris or other loose particulate.
- **Helpful Hint:** Use a transit to make level marks around the concrete wall 5 1/4 inches below the highest bond beam point. This allows quick leveling of the form, dealing with slight irregularities of the concrete.

### INSTALLATION

1. Pre-arrange form bands to avoiding having a break in a tight radius. Use a sharp knife to cut forms and miter for 45 & 90 degree angle corners. Do not use a hand saw.
2. Place a spear approximately every 12 inches along the bond beam. On both sides of any break, use a spear as close to break as spacing will allow.

For inner and outer curved installations, see other side for *Bending Instructions*.

3. Place the form band against the top corner of the bond beam with the square tongue of the form resting on top.
4. While holding the form against the bond beam, push the spear through the tongue of the form band having the end protruding the outer side of the form at the line. The depth of spear penetration is correct when the square lip of the spear comes to rest directly adjacent to the tongue of the form.
5. When the spear has been positioned properly, place the upper hole of a plastic bracket over the protruding spear, followed by sliding the self-locking button onto the sharp end of the spear. Push button until it audibly clicks once.

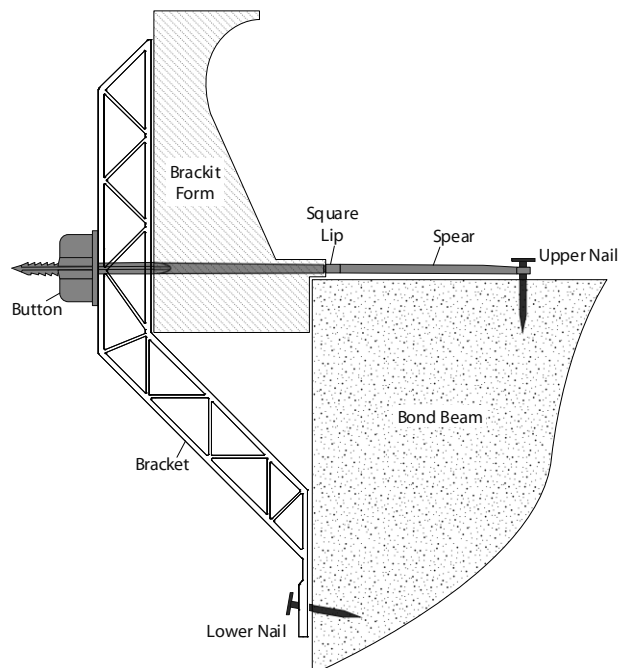

6. Adjust the bottom edge of the bracket to the level line from the transit while keeping it vertical.
7. Using a hammer, drive a supplied concrete nail through the hole in the end of the bracket, at a slightly downward angle, anchoring the leveled bracket to the concrete.
8. Holding the eyelet end of the spear, pull the spear to set the form firmly against the bond beam. Secure by driving a supplied concrete nail through the hole in the end of the spear.
9. With the spear nailed in place, push the button firmly against outside of the bracket to snugly ratchet form band against bond beam. Option: Install Nose, Flair or French Caps in line with Control Joints at this time.

## INSTALLATION - CONTINUED

10. It is always advisable to remove 1/2 shovel of dirt from behind the back edge of the bond beam approximately every 4 feet, to insure against any inward movement of the deck. It is also advisable to lightly spread sand on the bond beam to prevent the concrete deck from adhering to the bond beam. Mastic or asphaltic cement can be applied behind the spears if a water seal is desired.
11. While pouring the concrete, tap the outside of the form band with your hand to remove voids and holes bringing sufficient creme to the surface. **Note:** Do not pre-grout the face of the form.
12. When the concrete has solidified to the point where the form can be removed, rotate the button, severing the spear behind the surface of the concrete. Remove detached spear and button from bracket allowing the bracket to rotate, hanging down. Then, the form band is removed revealing the cantilever edge. Float the surface of the edge with a small section of form band dipped in water. After finishing the deck, remove lower nails to retrieve the reusable brackets.

## BENDING INSTRUCTIONS

In order to form tight radii without breaking the form bands, follow these procedures:

1. On inside radii, place two filament tape strips on the face of the form (in sufficient lengths to encompass the curve) below the tongue and place one in the upper curved form area as shown in Diagram 1.
2. For outside radii, place two strips of filament tape as shown in Diagram 2. Duct tape may also be used.
3. After the filament tape is in place, pre-bend the form band before placing the form against the bond beam. Bend forms to a tighter radius than where intended. Forms are best bent slowly, making multiple passes.

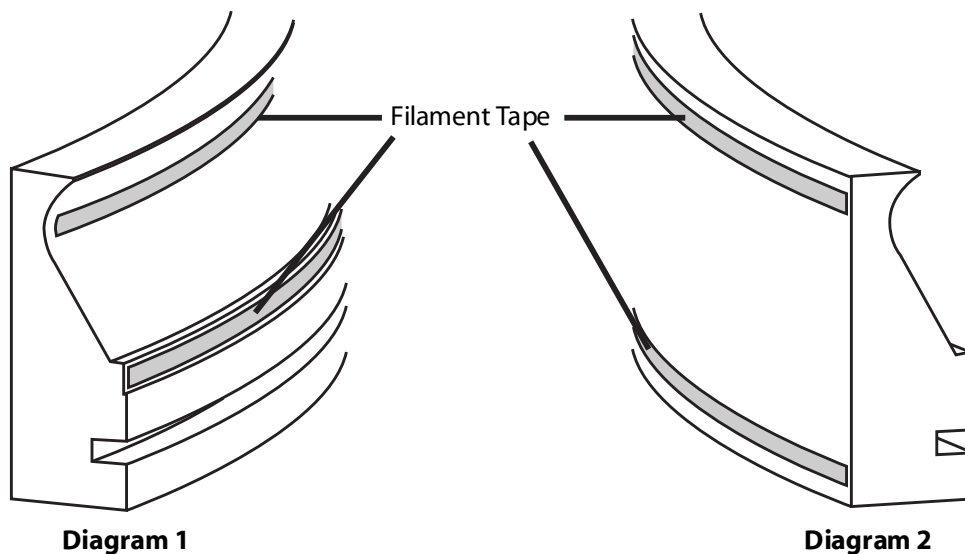

Diagram 1

Diagram 2



# Forms for Fiberglass Pools with Angled Pool Walls

Mortex Fiberglass cantilever deck forms are designed and engineered for practically any in-ground fiberglass pool. Our Fiberglass forms come with either our advanced spear and button system or tie wires to accommodate varying edge widths.

- Secure anchoring system allows the contractor to install a cantilever form that will stay.
- Angled shape for use with fiberglass pools with non-vertical walls.
- When side walls are approaching vertical and tile is installed, we recommend using our standard forms.



Product Detail	Description
Coverage	112 ft. of Form Bands and Cove Strip (34.13 m)
Contents	14 - 8 foot lengths (2.43 m); Fiberglass attachment pack containing 110 tie wires, 110 screws and Filament Tape
Ctn. Measurements	13" x 13" x 102" (33 cm x 33 cm x 259 cm)
Weight	24 lbs (10.9 kg)
Shipping Information	UPS, FedEx, Freight Truck, Ocean or Air

Catalog Item #	Description
FFGF	Fiberglass Form - French Curve - White Cove Strip - Tie Wire
FFGFCC	Fiberglass Form - French Curve - Charcoal Cove Strip - Tie Wires
FFGFCCG	Fiberglass Form - French Curve - Gray Cove Strip - Tie Wires
FFGFCT	Fiberglass Form - French Curve - Tan Cove Strip - Tie Wires
FFGK	Fiberglass Form - Keystone - White Cove Strip - Tie Wires
FFGKCC	Fiberglass Form - Keystone - Charcoal Cove Strip - Tie Wires
FFGKCCG	Fiberglass Form - Keystone - Gray Cove Strip - Tie Wires
FFGKCT	Fiberglass Form - Keystone - Tan Cove Strip - Tie Wires
FFGP	Fiberglass Form - Poly - White Cove Strip - Tie Wires
FFGPCC	Fiberglass Form - Poly - Charcoal Cove Strip - Tie Wires
FFGPCCG	Fiberglass Form - Poly - Gray Cove Strip - Tie Wires
FFGPCT	Fiberglass Form - Poly - Tan Cove Strip - Tie Wires
FXSPS	Spear Pack with Screws Attachment Pack - 110 each
FXTBS	Tie Bag with Screws Attachment Pack - 110 each

\* All Forms are also available with a Spear Pack with Screws instead of Tie Wires.

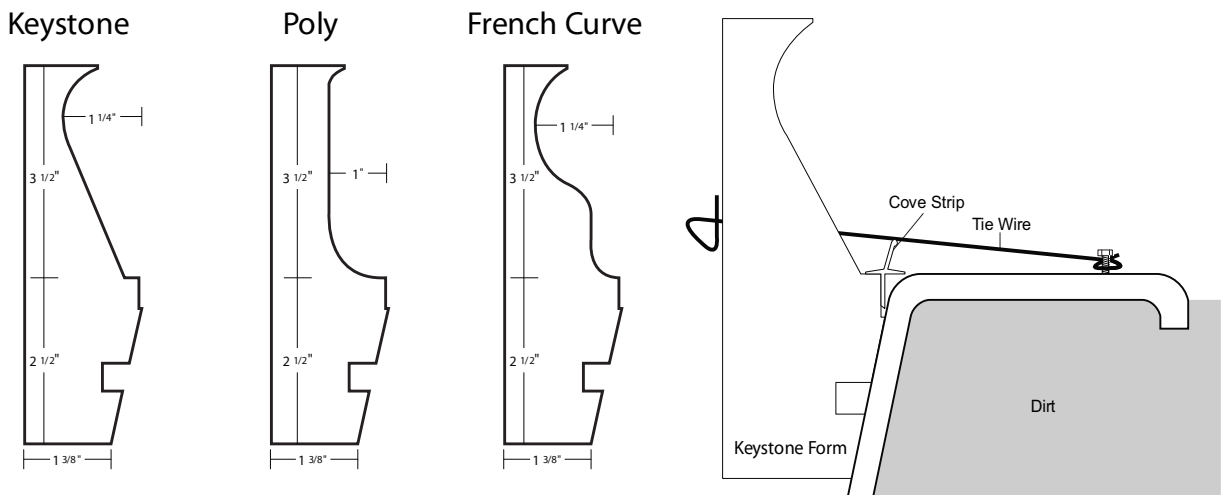

# Rite Strip

Rite Strips are L shaped PVC extrusions used to minimize the large radius on the top of a fiberglass pool for the use of a cantilever form.

- Cove Strip can be used with Rite Strip to form a water stop and assist with alignment.
- Spear & Button or Tie Wire attachments can be used depending on the size of the lip of the fiberglass pools.
- Available in straight or radius cut strips.

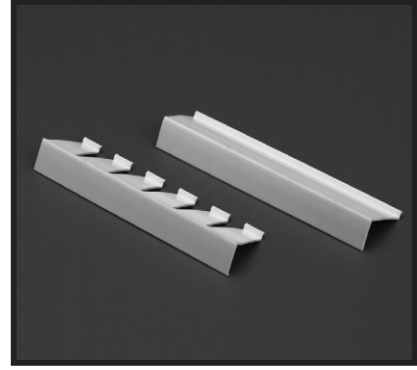

Product Detail	Description
Coverage	112 ft. of Straight or Radius Cut Rite Strips
Carton Contents	112 feet in 14 - 8 foot lengths # 8 x 1" self tapping screws provided for mounting the strips
Carton Measurement	6 1/2" x 3 1/2" x 97" (16.5 cm x 8.9 cm 246.4 cm)
Weight	Radius Cut: 8 lbs (3.6 kg) Straight Cut: 9 lbs (4.1 kg)
Shipping Information	UPS, FedEx, Freight Truck, Ocean or Air

Product Detail	Description
Coverage	112 ft. of Straight or Radius Cut Rite Strips
Carton Contents	14 - 8 foot lengths or form bands and Rite Strip, #8 x 1" self tapping screws provided for mounting the strips Option of Spear & Button or Tie Wire Attachment pieces
Carton Measurement	13" x 13" x 102" (33 cm x 33 cm x 259 cm)
Weight	24 lbs (10.9 kg)
Shipping Information	UPS, FedEx, Freight Truck, Ocean or Air

Catalog Item #	Description
FXRSRCW	Rite Strip Only - Radius Cut - White
FXRSW	Rite Strip Only - White
FKRST	Keystone Form - Straight Rite Strip - Tie Wires - Screws
FKRSRCT	Keystone Form - Radius Cut Rite Strip - Tie Wires - Screws
FKRS	Keystone Form - Straight Rite Strip - Spears & Buttons - Screws
FKRSRC	Keystone Form - Radius Cut Rite Strip - Spears & Button - Screws
FPRST	Poly Form - Straight Rite Strip - Tie Wires - Screws
FPRSCT	Poly Form - Radius Cut Rite Strip - Tie Wires - Screws
FPRS	Poly Form - Straight Rite Strip - Spears & Buttons - Screws
FPRSRC	Poly Form - Radius Cut Rite - Spears & Buttons - Screws
FSEFRST	Stone Edge Form - Straight Rite Strip - Tie Wires - Screws
FSEFRSCT	Stone Edge Form - Radius Cut Rite Strip - Tie Wires - Screws
FSEFRS	Stone Edge Form - Straight Rite Strip - Spears & Buttons - Screws
FSEFRSRC	Stone Edge Form - Radius Cut Rite Strip - Spears & Buttons - Screws

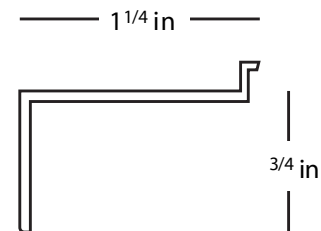
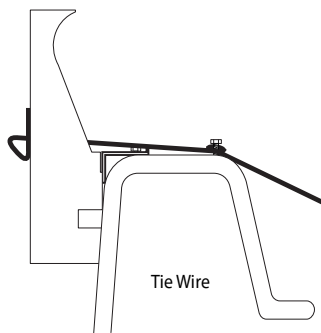
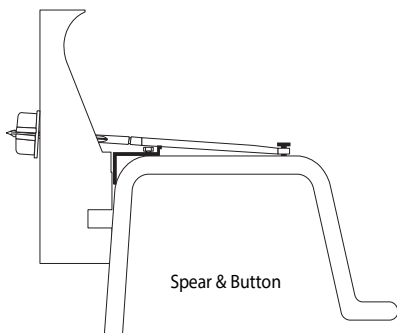

# Key-Lock™ Forms for Vinyl Liner Pools

Key-Lock™ forms offer an advanced attachment system for vinyl liner pools. Simple and easy to secure with keys that push through the form into the liner track, allowing the form to be set quickly. The key is locked into position with just a quarter turn of the handle.

## PVC Track

- Radius cut retainer shapes allows designers and contractors endless options in pool shapes.
- Key-Lock Keys are reusable.
- Forms are light weight and disposable after the job.

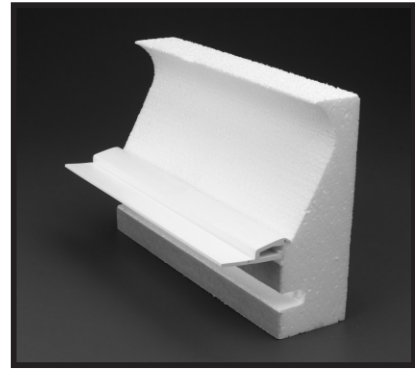

PVC Track

## Aluminum Track

- Aluminum liner tracks provide the strength to last in extreme cold weather conditions.
- Time Savings - Lined screw placement options for mounting.
- Cost Savings - 15% lighter and stronger than previous track design.
- Tempered Aluminum made in the USA
- Rounded front bevel for less liner wear, better bead locking inside.
- Specifically designed for Key-Plus keys (Gray in color.)

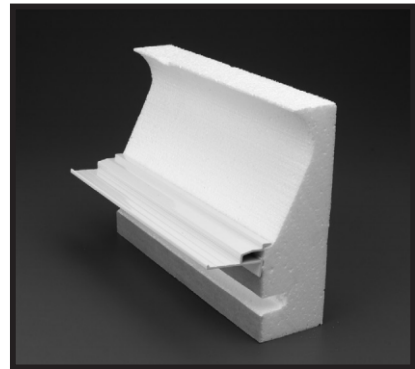

Aluminum Track

# PVC Liner Tracks

Key-Lock™ Liner tracks are used to hold the liner into a vinyl liner pool. They are made of PVC, come in the color white and are available in straight or radius cut lengths.

- Provides an economical alternative to the Aluminum track.

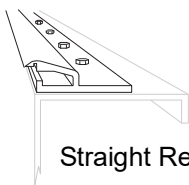

Straight Retainer

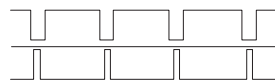

Radius Cut Retainer

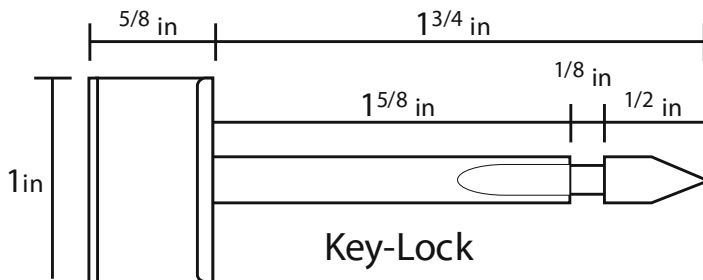
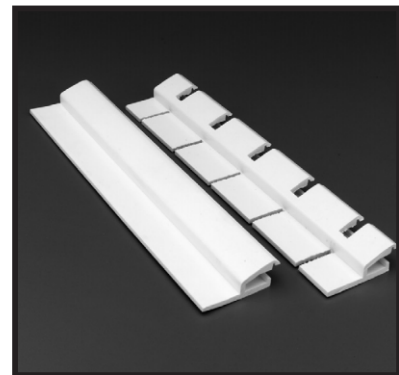

**Black colored Keys are used with PVC track.**

# Key-Lock™ Forms for Vinyl Liner Pools

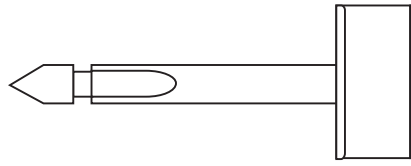

The patented Key-Lock system consists of a special key to be inserted, twisted for locking and unlocking with ease and speed.

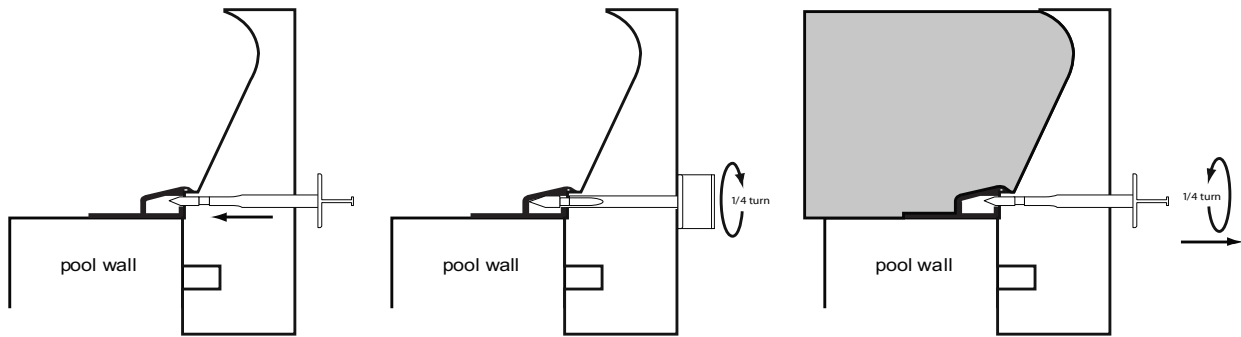

## Aluminum Liner Tracks

Key-Lock Liner tracks are used to hold the liner into a vinyl liner pool. They are made of heavy strength aluminum and are available in straight or radius cut lengths. Aluminum liner tracks provide the strength to last in extreme cold weather conditions.

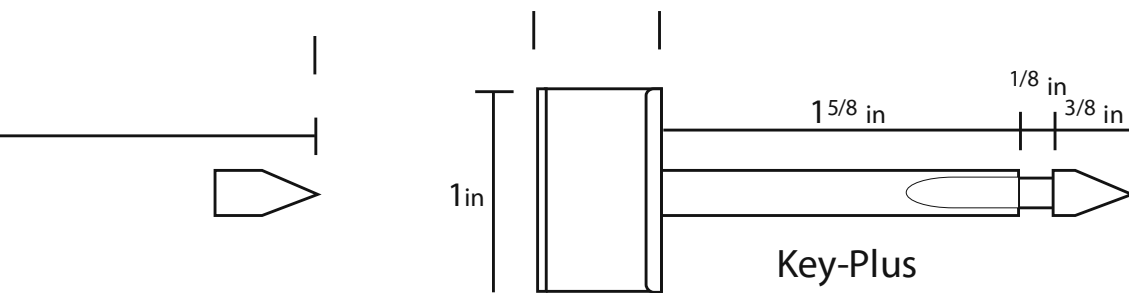
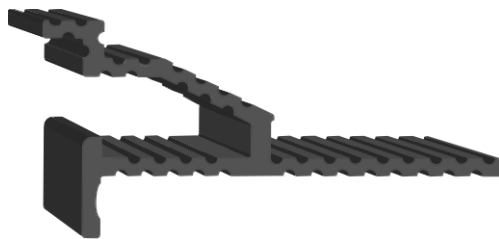
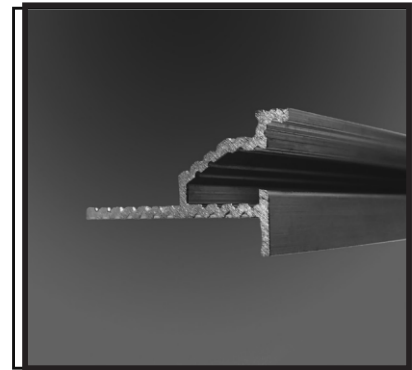

Gray colored Keys are used with the Aluminum track.

# Vinyl Liner Forms / Track Codes

## Aluminum Top Mount Tracks & Forms

For installing a Vinyl Liner Pool

Catalog Item #	Description
<b>Straight</b>	
FXALR	Aluminum Top Mount Track (Track Only)
FKLAK	Aluminum Top Mount Track + Keystone Forms + Key Pack
FKLAP	Aluminum Top Mount Track + Poly Forms + Key Pack
FKLASE	Aluminum Top Mount Track + Stone Edge Forms + Key Pack
FKLAF	Aluminum Top Mount Track + French Curve Forms + Keys Pack
<b>Radius Cut</b>	
FXARC	Aluminum Top Mount Radius Cut Track (Track Only)
FKLAKRC	Aluminum Top Mount Radius Cut Track + Keystone Forms + Key Pack
FKLAPRC	Aluminum Top Mount Radius Cut Track + Poly Forms + Key Pack
FKLASERC	Aluminum Top Mount Radius Cut Track + Stone Edge Forms + Key Pack
FKLAFRC	Aluminum Top Mount Radius Cut Track + French Curve Forms + Key Pack
<b>2 foot piece - Radius Track</b>	
FXA6RI	Aluminum Top Mount 6" Radius Inside Track (Track Only) - 2 foot piece

Product Detail	Description
Coverage	112 ft. of Form Bands and Aluminum Straight or Radius Cut Liner Track (34.13 m)
Contents	14 - 8 foot lengths (2.43 m) of Form Bands and Track One roll of Filament Tape; Key pack including 110 Keys
Ctn Measurements	Product comes in two separate boxes banded together: 13" x 13" x 102" (33cm x 33cm x 259cm) and 3 1/2" x 6 1/2" x 97" (9cm x 17cm x 246cm)
Weight	50 lbs total (22.6 kg)
Shipping Information	UPS, FedEx, Freight Truck, Ocean or Air

## PVC Liner Tracks & Forms

Catalog Item #	Description
FXR	Key-Lock Liner Track Only
FKL	PVC Straight Track + Keystone Form + Key Pack
FKLP	PVC Straight Track + Poly Form + Key Pack
FKLSEF	PVC Straight Track + Stone Edge Form + Key Pack
FKLF	PVC Straight Track + French Curve Form + Key Pack
FXRCE	PVC Radius Cut Track - Exchange (8 foot section)
FXRCR	Key-Lock Radius Cut - Track Only
FKLRC	PVC Radius Cut Track + Keystone Form + Key Pack
FKLPRC	PVC Radius Cut Track + Poly Form + Key Pack
FKLSEFRC	PVC Radius Cut Track + Stone Edge Form + Key Pack
FKLFRRC	PVC Radius Cut Track + French Curve Form + Key Pack

When you order the FXRCE along with the FKLF, FKL or FKLP we will exchange 8 feet of the straight retainer for 8 feet of the radius cut retainer.

Product Detail	Description
Coverage	112 ft. of Form Bands and Liner Track (34.13 m)
Contents	14 - 8 foot lengths of Form Bands & Track (2.43 m) One roll of Filament Tape & Key pack (110 Keys)
Ctn Measurements	13" x 13" x 102" (33 cm x 33 cm x 259 cm)
Weight	35 lbs. (17 kg)
Shipping Information	UPS, FedEx, Freight Truck, Ocean or Air

### Key Attachment Packs

FXKP	Key Pack (110 keys - Black) - For use with Mortex Key-Lock PVC Tracks.
FXKPL	Key Plus (110 keys - Gray) - For use on Mortex Key-Lock Aluminum Tracks.

# Renovation Forms

Mortex Renovation Forms are an innovative solution to traditional coping replacement.

- The Renovation Form can be placed along the tile to accommodate a desired concrete thickness of 2 1/2".
- Commonly used to replace brick coping.
- Form height is tall enough to accommodate use of the Control Joint.
- Available in a popular Keystone-Like shape

**Note:** This form shape is NOT compatible with Flair Caps.

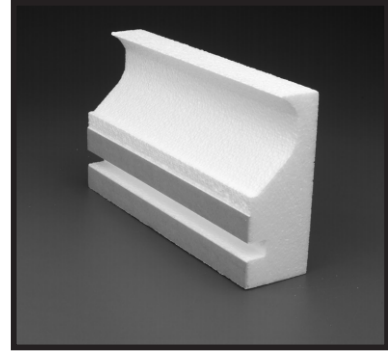

Product Detail	Description
Coverage	112 ft. of Form Band and White Cove Strip (34.13 m)
Contents	14 - 8 foot lengths (2.43 m); Spear Pack containing 110 Spear & Buttons, 120 nails and One roll of Filament Tape
Ctn Measurements	13" x 13" x 102" (33 cm x 33 cm x 259 cm)
Weight	24 lbs (10.9 kg)
Shipping Information	UPS, FedEx, Freight Truck, Ocean or Air

Catalog Item #	Description
FRMK	Renovation Form - Keystone w/o Cove Strip (Form Bands Only)
FRMKC	Renovation Form - Keystone with Cove Strip and Spear Pack

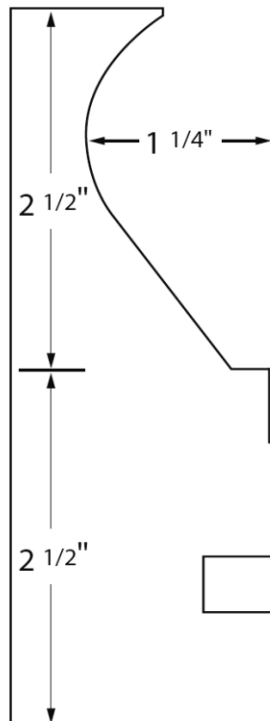

# Step Forms

Mortex's step liner form is a convenient and decorative alternative to traditional forms. The exclusive Mortex angled edge makes smaller form footprint and allows float access closer to corner of the step.



- Varying break points on the form allow for full 4", 6", and 8" high steps
- Angled form bottom allows for float access, not available with wood forming
- While it cushions against concrete, it can be stripped and finished much earlier than traditional forms
- Bender Boards, or wooden forms may be used to set radius steps

Product Detail	Description
Coverage	Keystone, Poly, French Curve, Glow Rite: 40 ft. per carton (12.1 m); Hemi: 28 ft. per carton (8.5 m)
Contents	Keystone, Poly, French Curve, Glow Rite: 10 - 4 ft. lengths; Hemi Step Forms: 7 - 4 ft. lengths
Ctn Measurements	13" x 13" x 52" (33 cm x 33 cm x 132.1 cm)
Weight	Keystone, Poly, French Curve, Hemi: 7lbs (3.2 kg); Glow Rite: 11 lbs (5 kg)
Shipping Information	UPS, FedEx, Freight Truck, Ocean or Air

Catalog Item #	Description
FSFLFC	Step Form Liner - French Curve
FSFLHEMI	Step Form Liner - Hemi
FSFLK	Step Form Liner - Keystone
FGRSF	Step Form Liner - Glow Rite Flat Track
FGRSR	Step Form Liner - Glow Rite Round Track
FSFLP	Step Form Liner - Poly

## INSTALLATION INSTRUCTIONS

1. The top of the step form should be placed even with the top of the wood form.
2. Before putting the form in place, cut the form at the break point with a sharp knife for the desired height (see diagram).
3. The 1/2 space between the bottom of the wood and the bottom of the form liner allows for float and trowel access.
4. Place the step form on the inside of the wooden form. Secure with nails or tape.
5. Mortex forms can be stripped and finished much earlier than traditional forms. While the concrete is still fresh, you can use a small section of the form to float and trowel the edge.

Height of the complete form is 8".

Exclusive Mortex angled edge makes smaller form footprint and allows float access closer to corner of step.

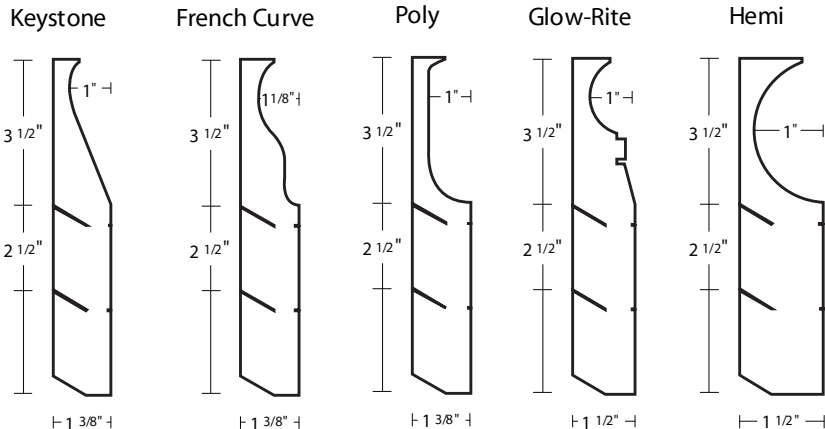
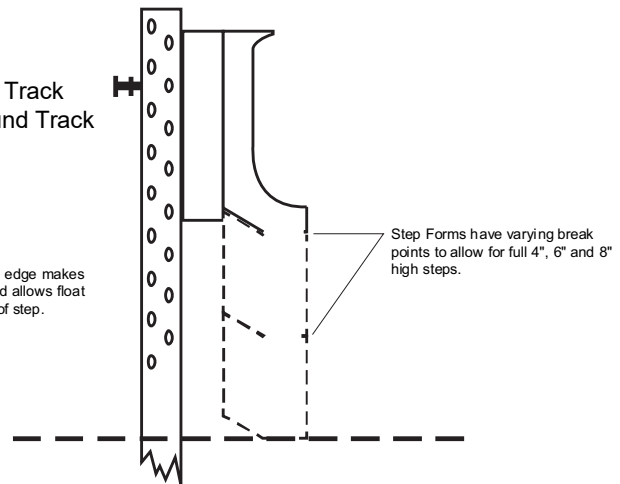

# Cornice Moulding Forms for Wall Tops

Mortex Cornice Moulding Forms are designed for the easiest form application of any disposable wall cap in the industry. Use Cornice Moulding Forms to cast various cantilever styles for concrete caps, block walls, glass block walls, and planters.



- A Wall Tie Kit provides the attachment pieces to securely fasten the forms together.
- Adjustable width of cap is made fast by pre-placed tie holes. Use multiple ties chained together for wider than normal uses.
- No working around cumbersome clamps or other mountings.

## Cornice Moulding Forms - Keystone

Product Detail	Description
Contents	112 ft. (34.14 m) of Form Strip in 14 - 8 ft. (2.43 m) lengths & Attachment package.
Measurements	13" x 13" x 102" (33 cm x 33 cm x 259 cm)
Weight	24 lbs (10.9 kg)
Shipping Info	UPS, FedEx, Freight truck, Ocean or Air

## Cornice Moulding Forms - Poly

Product Detail	Description
Contents	128 ft. (39.01 m) of Form Strip in 16 - 8 ft. (2.43 m) lengths & Attachment package.
Measurements	13" x 13" x 102" (33 cm x 33 cm x 259 cm)
Weight	24 lbs (10.9 kg)
Shipping Info	UPS, FedEx, Freight truck, Ocean or Air

## Cornice Moulding Forms - French Curve

Product Detail	Description
Contents	128 ft. (39.01 m) of Form Strip in 16 - 8 ft. (2.43 m) lengths & Attachment package.
Measurements	13" x 13" x 102" (33 cm x 33 cm x 259 cm)
Weight	24 lbs (10.9 kg)
Shipping Info	UPS, FedEx, Freight truck, Ocean or Air

## Cornice Moulding Forms - Commercial

Product Detail	Description
Contents	80 ft. (24.39 m) of Form Strip in 10 - 8 ft. (2.43 m) lengths & Attachment package.
Measurements	13" x 13" x 102" (33 cm x 33 cm x 259 cm)
Weight	24 lbs (10.9 kg)
Shipping Info	UPS, FedEx, Freight truck, Ocean or Air

## Cornice Moulding Forms - OG

Product Detail	Description
Contents	56 ft. (17.07 m) of Form Strip in 7 - 8 ft. (2.43 m) lengths each & Attachment package.
Measurements	13" x 13" x 102" (33 cm x 33 cm x 259 cm)
Weight	24 lbs (10.9 kg)
Shipping Info	UPS, FedEx, Freight truck, Ocean or Air

## Wall Tie Kit - for additional ties, dogs and nails.

Product Detail	Description
Contents	Box: 100 Ties & Dogs (buttons), 120 nails
Carton Measurements	Varies
Weight	Varies
Shipping Information	UPS, FedEx, Freight Truck, Ocean or Air



# Cornice Moulding Forms for Wall Tops

Catalog Item #	Description
FMC	Cornice Moulding Form - Commercial
FMFC	Cornice Moulding Form - French Curve
FMK	Cornice Moulding Form - Keystone
FMOG	Cornice Moulding Form - O-G Edge
FMP	Cornice Moulding Form - Poly
FGRWF	Glow-Rite Cornice Moulding Form - Flat
FGRWR	Glow-Rite Cornice Moulding Form - Round
FXWT	Wall Tie Kit (for and additional attachment kit)

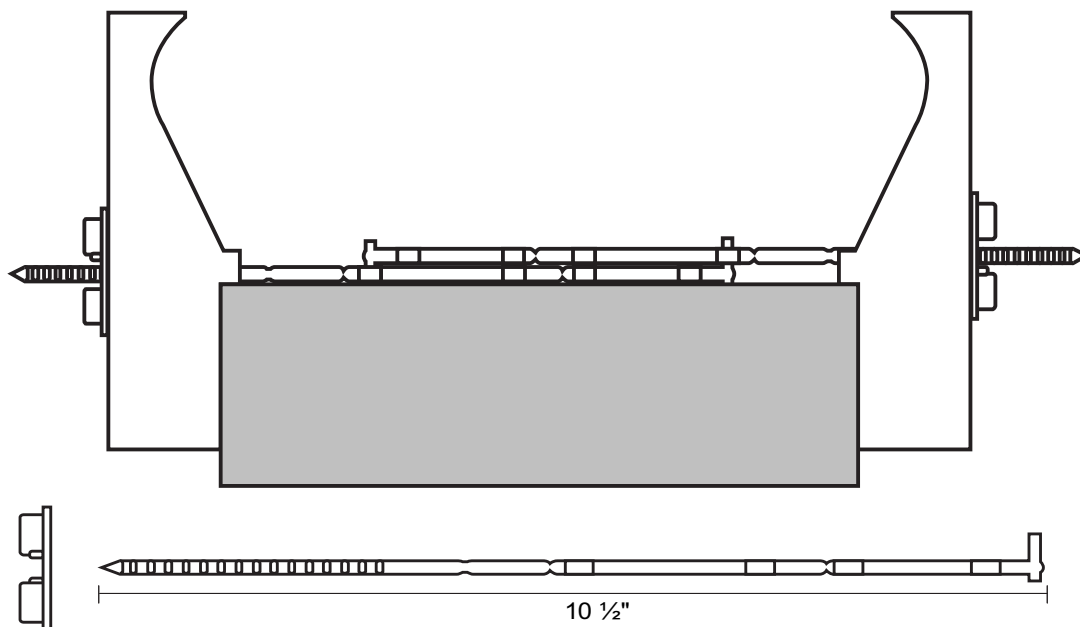

## INSTRUCTIONS:

Thread the Wall Ties through the forms and connect in the middle to your desired width. Assemble on the top of the wall with the dogs (buttons) on the back of the forms.

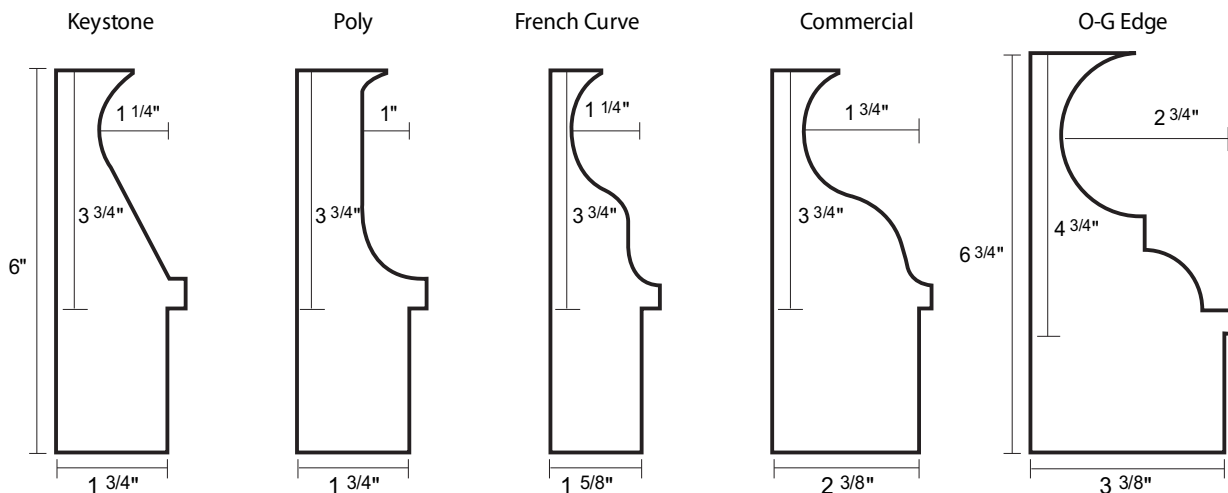

# Countertop Forms

Now you can have countertops made of one of the most widely used, versatile construction materials: concrete. Not only is concrete capable of taking on any shape imaginable for a countertop, but it can be adapted to complement any decor.

- Feel and longevity of concrete.
- Variety of edge shapes to choose from.
- Limitless versatility.

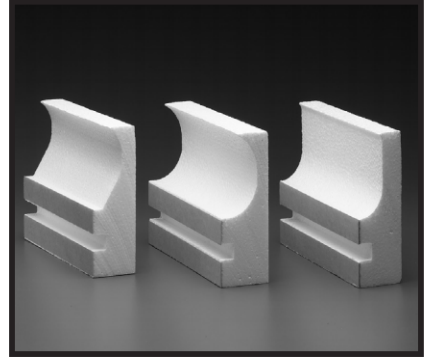

Product Detail	Description
Coverage	44 ft. per carton (13.4 m); Exception: Deco 36 ft. (13.4 m)
Contents	11 - 4' lengths, 8' sink block, Spears, Buttons, Nails
Carton Measurements	10" x 10" x 52" (25.4 cm x 25.4 cm x 132 cm)
Shipping Weight	7 lbs (3.2 kg)
Shipping Information	UPS, FedEx, Freight Truck, Ocean or Air

Item #	Description	Item #	Description
FCTFK	Countertop Form - Keystone (44 ft.)	FCTFD	Countertop Form - Deco (36 ft.) *
FCTFP	Countertop Form - Poly (44 ft.)	FCTFGS	Countertop Form - Gemstone (44 ft.) *
FCTFH	Countertop Form - Hemi (44 ft.)	FCTFI	Countertop Form - Impression (44 ft.) *
FCTFC	Countertop Form - French Curve (44 ft.) *		

**\* Special Order: 2-3 week lead time**

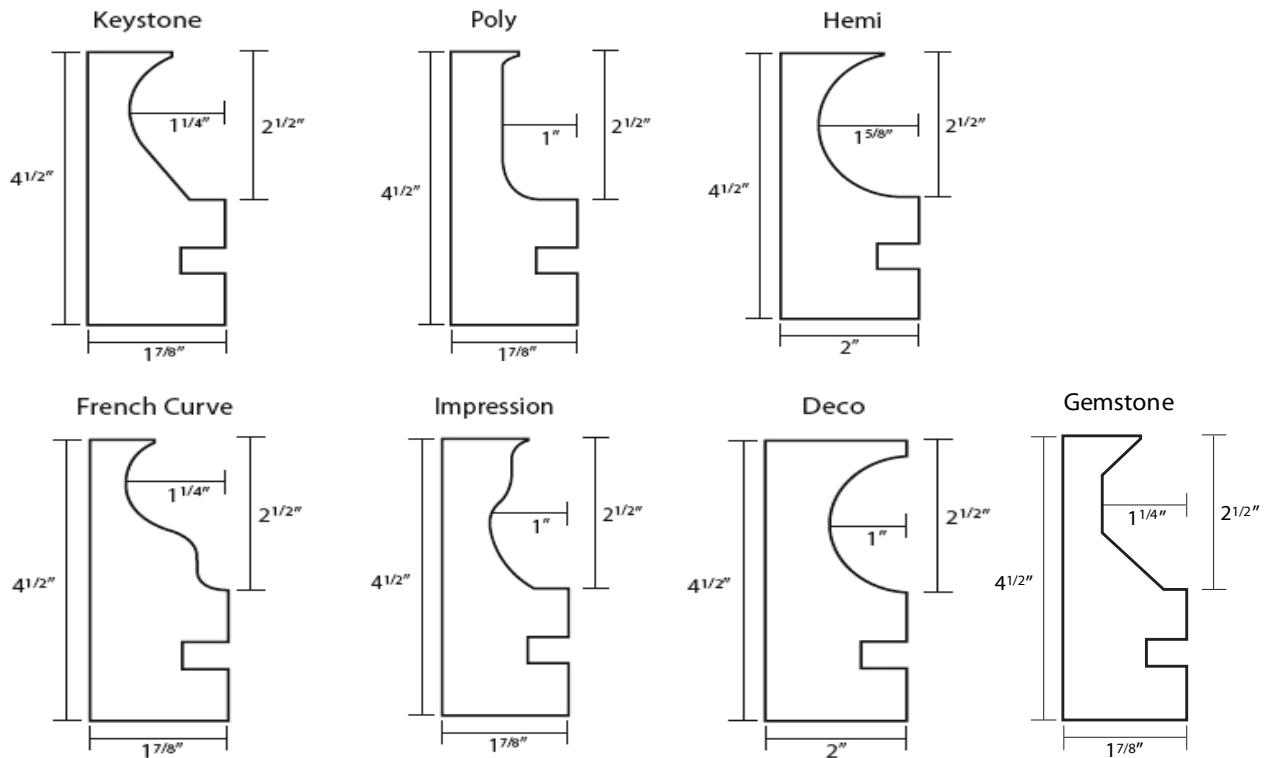

# Why choose Mortex?

## History of Mortex, Then & Today

Since our beginning in 1962, Mortex has been on the leading edge in the development and production of decorative and specialty concrete products. Throughout our beginning with the evolution of our Kool Deck® surfaces, we have strived to maintain and develop quality products while providing the utmost in personalized service. Our philosophy is produce the highest quality of products and delivering the best customer service for them.

## Quality Products

All products offered for sale at Mortex are manufactured in Tucson, AZ utilizing only the highest quality of raw materials and tested regularly for quality control purposes.

## Customer Service

Mortex is proud of the customer service level that we have been able to achieve and maintain since 1962. We provide representatives through the U.S. as well as in-house staff to provide the highest level of support.

## Technical Support

Technical support is available by telephone or email by contacting our office at 1-800-338-3225.

## Drop Shipping

Mortex will drop ship an Authorized Distributor's purchase order directly to their customer's location. Mortex maintains two (2) distribution warehouses located in Tucson, AZ and Atlanta, GA that will ensure timely arrival of your product.

*Thank you for your time and consideration of the Mortex line of products. We look forward to serving you in the future and the ability to let our actions speak louder than our words.*

## **Mortex Manufacturing Co., Inc.**

1818 West Price Street  
Tucson, AZ 85705-2217

**Phone** 520-887-2631

**Fax** 866-966-7839

**Toll Free** 800-338-3225  
Within U.S.A. only

**Internet** [mortex.com](http://mortex.com)

**Email** [office@mortex.com](mailto:office@mortex.com)

## **Business Hours**

Monday - Friday  
8:00 AM - 4:30 PM (Arizona)

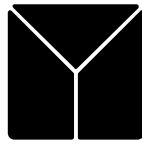

**MORTEX**

## Color Selections

All colors are approximate.

### Kool Deck® and Solement™



Adobe Buff



Aqua



Aztec Gold



Birch Gray



Coral Peach



Dove Gray



Dust Devil



Rose Pink



Sand Buff



Sedona Tan

### Designer Color Collection™



Island Tan



Mauve



T5



Terra Cotta

*Designer Colors are warmer to the touch due to their darker color.*

### Systemx®



Ivory



Tan

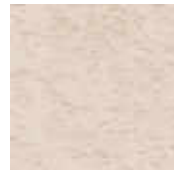

Almond



Malt

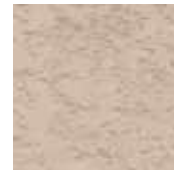

Taupe



Clay



Gold



Peach

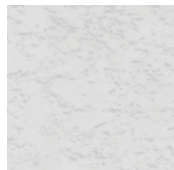

Gray



Rustic

### Control Joint™, Drain Rite®, Channel Rite™, and Pave Rite™

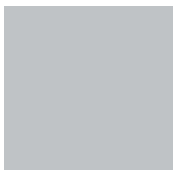

Gray



Charcoal



White



Marble



Tan

### Corporate Headquarters

1818 W. Price Street, Tucson, AZ 85705-2217 USA

Toll-Free 800.338.3225 Phone: 520.887.2631 Fax: 866.966.7839 [www.mortex.com](http://www.mortex.com)