

# Ad-Tex SPRAYER

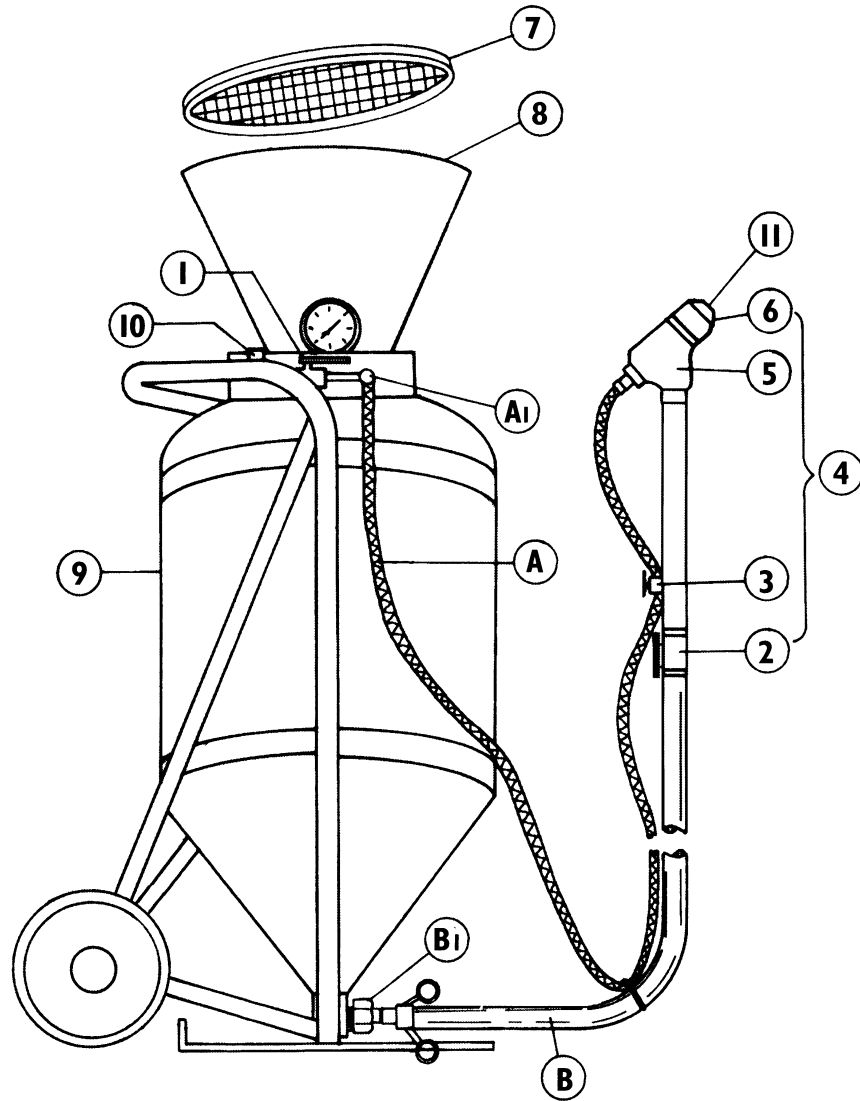

1. Air Supply Valve
2. Ball Valve
3. Air Valve
4. Gun Assembly
5. Nozzle
6. Nozzle Tip
7. Screen
8. Hopper
9. Tank
10. Air Regulator
11. Air Tube

- A. Air Hose
- A1. Air Hose Port
- B. Material Supply Hose
- B1. Material Hose Port

# AD-TEX SPRAYER

## Operating Instructions

### A. Hose Set-Up

1. Set air supply valve (1) to exhaust and remove cam-lock cap.
2. Connect nozzle air hose (A) to port (A1).
3. Connect material supply hose (B) to bottom of tank (B1).
4. Connect air supply hose (compressor) to port (C).

### B. Filling the Machine

1. On the gun assembly (4) close ball valve (2) and air valve (3).
2. Using a pistol type nozzle on a garden hose, wet screen (7), hopper (8), and inside of tank (9) thoroughly with water.
3. Place cap on tank, and lock handles in the closed position with the locking pin that is chained to the cap and move air supply valve (1) to charge position. **NEVER CHARGE THE TANK** with air without the locking pin properly through the handles and the bail thrown to secure it in place.
4. While air pressure is building up, adjust air regulator (10) to 15 psi for Keystone Kool Deck and Designer Colors, or 22 psi for Marquee.
5. Point nozzle (5) into a 5-gallon bucket and open air valve (3). Then, slowly open ball valve (2) until about one quarter open. When water stops coming from the nozzle, close ball valve (2).
6. Move air supply valve (1) to exhaust position. **WARNING DO NOT** make any attempt to remove cap, not even to remove locking pin, until pressure in tank (9) has been reduced to zero.
7. When tank pressure is zero, remove cam-lock cap.
8. Place appropriate screen (7) in hopper (8) and pour Keystone Kool Deck, Designer Color, or Marquee through screen. The machine has a capacity of 20 gallons.
9. When the desired amount of material has been placed in the tank (9) remove hopper (8) and clean the top and outside of cam-lock flange with a wet rag. Replace cap and lock handles in the closed position using the locking pin and then turn air supply valve (1) to charge position.

### C. Nozzle Set-Up

1. Screw nozzle tip (6) down until tight, then open two turns. Further adjustment may be necessary to obtain the proper spray pattern.
2. Place nozzle (5) in a clean empty 5-gallon bucket.
3. Open air valve (3) one turn.
4. Open ball valve (2) one quarter of the way open and run about 1 gallon of material into the bucket (return this material to mixer). Close ball valve (2). Do not close air valve (3). Allow it to remain open until you are completely through and have cleaned the sprayer.
5. You are ready to apply material to the deck.

### D. Applying Material

1. With air valve (3) slightly open, open ball valve (2) at least half to fully open.
2. Adjust air valve (3) so that it fans the stream of material into droplets. Too much air makes the droplets too small to generate the proper texture and can separate the sand from the cement. It should also be necessary to lightly respray to make the material stand up for a good texture.
3. Rotate the nozzle tip (6) side to side, in a quick motion while moving across the surface of the deck at a height of 3 to 5 feet.
4. If you can see the base concrete through the voids, apply more material.
5. If you get a burst of material and/or a rush of air, you are out of material. Close ball valve (2) and refill tank (9). See section B-6.

### E. Cleaning Machine

1. Drain machine of remaining material.
2. Open tank (9) as though recharging it. See section B-6.
3. First rinse the very bottom inside of tank (9), then rinse screen (7), hopper (8), and then the remaining inside of tank (9).
4. Pressurize tank and open ball valve (2) flushing water and material through hose and nozzle. **CAUTION** Be sure air valve (3) remains open during the complete cleaning cycle so it does not let cement get into and plug air tube (11).
5. Again, open tank as when recharging. See section B-6.
6. Remove nozzle tip (6) and rinse tip and nozzle (5).
7. Rinse locking cap, and using a pistol-type water hose nozzle, reach through the hole and direct the water spray against the top of the tank first, then the sides. Be sure the complete inside of the tank is rinsed thoroughly.
8. Have at least 3 gallons of water in tank and then recharge tank with air.
9. Open and close ball valve (2) several times to clean it, and check the last of the water to see if it is clean and free of cement and sand. If not clean, then repeat E-6 and E-7.
10. Close ball valve (2) and raise air pressure. Open air valve (3) to fully open to clear any cement that has entered air tube (11).
11. Depressurize tank, disconnect air hoses (A&C) and material hose (B). Leave locking cap open so that tank may completely dry out.

**NOTE:** The air compressor is not provided with the AD-TEX Sprayer.

#### AIR COMPRESSOR REQUIREMENTS

Minimum 4 cfm @ 40 psi  
Maximum 7 cfm @ 40 psi

(cfm = cubic feet per minute)  
(psi = pounds per square inch)

The bigger the compressor air tank, the quicker you will be able to spray material after pressurizing the sprayer.