

Pave Rite™

Paver Deck Draining Solution

Pave Rite is specially designed for superior drainage within paver decking. It is a two piece, linear, water channel draining system. Due to its design and heavy walled construction, warping and bowing found in other drain systems are greatly reduced. Pave Rite's full two inch top provides greater water flow from the deck surface, and it has the stylish look that is perfect for upscale paver installations.

All extrusions and compounding are done in-house to assure the highest quality.

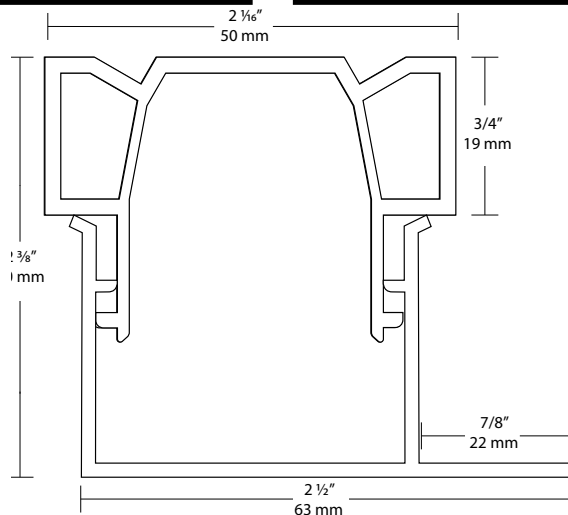

- Accessories
- Down Spouts
 - End Caps
 - Straight Spouts
 - End Spouts
 - 45 Degree Angles
 - 90 Degree Angles

Technical Information:

Carton Contents
80 feet per carton (24.38 m) 8 - 10 foot lengths (3.05 m)
Colors
White, Tan, Grey, Marble, Charcoal
Shipping Weight
65 lbs
Shipped by
Freight Truck, Ocean or Air

Available Colors:



Mortex Manufacturing Co., Inc.
1818 W. Price Street
Tucson, AZ 85705-2217
USA

Toll-Free: 800.338.3225
Phone: 520.887.2631
Fax: 866.966.7839

www.mortex.com